



DISTRICT PANCHAYATH KASARAGOD

EQUIP 2023

(Educational Quality Improvement Programme for class ten)

QUESTION POOL



Student Support Material for Class X

MATHEMATICS

ENGLISH MEDIUM



DIET KASARAGOD

.....

EQUIP 2023

Chief Editor : **Dr. Raghurama Bhat K.**
Principal, DIET Kasaragod

Editor : **Madhusoodanan V.**
Lecturer, DIET Kasaragod

Editorial Board : **Gireesh Babu A.**
Lecturer, DIET Kasaragod
: **Ashoka M.**
Teacher Educator, DIET Kasaragod

Resource Team

1. Gangadharan V. Vellangat, GFHSS Bekal
2. Preetha K.A, GHSS Patla
3. Santhosh Kumar K., GVHSS Kayyur
4. Krishna Prakash S, SNHS Perla
5. Balakrishna P., BEMHSS Kasaragod
6. Ajaykumar K.V., VPPMKPSGVHSS Trikaripur

DTP Layout & Cover design

Rubix Cyber Cafe, Iriyanni, Kasaragod

Prepared by : DIET Kasaragod

Printed & Published by : District Panchayath Kasaragod

.....



ആശംസ

വികേന്ദ്രീകൃത ആസൂത്രണത്തിലൂടെയും നിർവ്വഹണത്തിലൂടെയും കേരളത്തിലെ ആരോഗ്യ വിദ്യാഭ്യാസ മേഖലകളെ ദേശീയ തലത്തിൽ ഒന്നാമതെത്തിക്കാൻ നമുക്ക് കഴിഞ്ഞിട്ടുണ്ട്. ഈ നേട്ടങ്ങൾ കൈവരിക്കാൻ പ്രാദേശിക ഭരണകൂടങ്ങൾ സ്തുത്യർഹമായ പങ്കുവഹിച്ചു. കോവിഡ് പ്രതിസന്ധി രൂക്ഷമായപ്പോൾ കേരളത്തിലെ പൊതു വിദ്യാഭ്യാസ മേഖല നിശ്ചലമാകാതെ മുന്നോട്ടുകൊണ്ടുപോകാൻ നാമെല്ലാം കൈകോർത്തു പിടിച്ചുകൊണ്ട് ശ്രമിച്ചു. എന്നിരുന്നാലും മുഖാമുഖ പഠനാനുഭവങ്ങളുടെ അഭാവം വിദ്യാർത്ഥികൾക്ക് പഠനവിടവുകളും പഠനനഷ്ടങ്ങളും ഉണ്ടാക്കിയിട്ടുണ്ട്. ഈ പ്രശ്നം പരിഹരിക്കുന്നതിനുവേണ്ടി കാസറഗോഡ് ജില്ലാ പഞ്ചായത്തിന്റെ നേതൃത്വത്തിൽ പൊതുവിദ്യാഭ്യാസ വകുപ്പും കാസറഗോഡ് ഡയറ്റും ഒത്തുചേർന്ന് നടപ്പാക്കുന്ന 'എക്വിപ്പ്' (EQUIP) പഠനപരിപോഷണ പരിപാടിക്ക് എല്ലാ പിന്തുണയും ഉറപ്പുതരുന്നു. പത്ത് വർഷത്തെ പഠനപ്രവർത്തനങ്ങളുടെ മികവിന്റെ അടയാളമായി മാറുകയാണ് പത്താം ക്ലാസിലെ വാർഷിക പരീക്ഷ. അറിവിന്റെ തെളിമയോടെ ഓരോ വിദ്യാർത്ഥിക്കും പരീക്ഷ എഴുതാൻ കഴിയണം. വിദ്യാർത്ഥികളുടെ ജീവിതത്തിലെ ഏറ്റവും പ്രധാനപ്പെട്ട പരീക്ഷകൾക്ക് വേണ്ടി തയ്യാറാക്കിയ ചോദ്യബാങ്കിന് എല്ലാവിധ ആശംസകളും നേരുന്നു. നന്നായി പഠിക്കുക. പരീക്ഷയെ സധൈര്യം നേരിടുക. തളരാതെ മുന്നോട്ട്. വിജയം നിങ്ങളോടൊപ്പമുണ്ട്. ആശംസകൾ.

ശ്രീമതി ബേബി ബാലകൃഷ്ണൻ

ജില്ലാ പഞ്ചായത്ത് പ്രസിഡന്റ്

കാസറഗോഡ്



ആശംസ

കാസർകോട് ജില്ലാ പഞ്ചായത്തിന്റെ നേതൃത്വത്തിൽ ജില്ലയിലെ പൊതുവിദ്യാഭ്യാസ മേഖലയെ ശക്തിപ്പെടുത്തുന്നതിന് നിരവധി പ്രവർത്തനങ്ങളാണ് നടന്നുവരുന്നത്. കോവിഡ്-19 നമ്മുടെ ശ്രമങ്ങളെ പിന്നോട്ടടിക്കാൻ ഒരു പരിധിവരെ കാരണമായിട്ടുണ്ടെങ്കിലും, അതിനെയാക്കെ അതിജീവിച്ചുകൊണ്ട് പൊതുവിദ്യാഭ്യാസ മേഖലയെ പൂർവ്വാധികം കരുത്തോടെ നാം മുന്നോട്ട് നയിക്കുകയാണ്. ഈ ഘട്ടത്തിലാണ് കാസറഗോഡ് ജില്ലാ പഞ്ചായത്തും, പൊതുവിദ്യാഭ്യാസ വകുപ്പും, വിദ്യാഭ്യാസ പരിശീലന കേന്ദ്രവും (DIET) പത്താം ക്ലാസ് വിദ്യാർത്ഥികളുടെ പഠനവിടവുകൾ പരിഹരിക്കുന്നതിനും ആത്മവിശ്വാസത്തോടെ പൊതുപരീക്ഷയെ നേരിടാൻ അവരെ പ്രാപ്തരാക്കുന്നതിനും വേണ്ടി പഠനപരിപോഷണ സാമഗ്രി തയ്യാറാക്കുന്നത്. കുട്ടികളുടെ അക്കാദമിക് മികവ് ഉറപ്പുവരുത്തിക്കൊണ്ട് മികച്ച ഗ്രേഡുകൾ നേടാൻ അവരെ സജ്ജമാക്കാൻ 'എക്സിറ്റ് 2023' എന്ന പേരിൽ ഡയറ്റ് കാസർകോട് തയ്യാറാക്കിയ ഈ പദ്ധതിക്ക് കഴിയട്ടെയെന്ന് ആശംസിക്കുന്നു.

സ്നേഹപൂർവ്വം

അഡ്വ. സരിത എസ്.എൻ.

ആരോഗ്യ-വിദ്യാഭ്യാസ സ്ഥിരം സമിതി

അധ്യക്ഷ, ജില്ലാ പഞ്ചായത്ത്,

കാസർകോട്



ആശംസ

ഈ വർഷം എസ്.എസ്.എൽ.സി. പരീക്ഷ എഴുതുന്ന വിദ്യാർത്ഥികൾക്ക് ജില്ലാ പഞ്ചായത്തിന്റെയും ഡയറ്റിന്റെയും സഹായ സംരംഭമാണ് **EQUIP** പഠനപുസ്തകം. ഇംഗ്ലീഷ്, കണക്ക്, ഫിസിക്സ്, കെമിസ്ട്രി, ബയോളജി, സോഷ്യൽ സയൻസ് എന്നീ വിഷയങ്ങളെ അടിസ്ഥാനമാക്കി യൂണിറ്റുകൾ സമഗ്രമായും കണ്ട് ഓരോ പുസ്തകവും, ഭാഷാ വിഷയങ്ങളെ മൊത്തമായി ഉൾക്കൊള്ളിച്ച് ഒരു പുസ്തകമായുമാണ് EQUIP തയ്യാറാക്കിയിരിക്കുന്നത്.

ഉത്തരം പഠിക്കുന്നതിന് പകരം ചോദ്യങ്ങളിലൂടെ ഉത്തരത്തിലേക്ക് എത്തി ചിന്താശേഷിയും രചനാ രീതിയും പരിശീലിച്ച് പാഠഭാഗത്തിന്റെ ആശയം ഉൾക്കൊള്ളുക എന്ന രീതിയാണ് EQUIP അടിസ്ഥാനമാക്കുന്നത്.

വിദ്യാലയങ്ങളിലെ പരിചയ സമ്പന്നരായ അധ്യാപകർ നൽകുന്ന നിർദ്ദേശത്തോടെ കോറോണ കാലത്തെ പഠന വിടവ് അനുഭവിച്ച ഒരു ബാച്ചിന് ആവശ്യമായ കൈത്താങ്ങ് EQUIP നൽകും.

EQUIP പഠനസാമഗ്രി ജില്ലയിലെ പത്താം ക്ലാസ്സ് വിദ്യാർത്ഥികൾക്ക് ഏറ്റവും മികച്ച വിജയത്തിനുള്ള ചവിട്ടുപടി ആവട്ടെയെന്ന് ആഗ്രഹിക്കുന്നു. ജില്ലാ പഞ്ചായത്തിന്റെയും ഡയറ്റിന്റെയും സംരംഭത്തിന് എല്ലാ ആശംസകളും നൽകുന്നു.

വാസു സി.കെ.
ജില്ലാ വിദ്യാഭ്യാസ ഉപഡയറക്ടർ
കാസർകോട്



ആമുഖം

ജില്ലയിലെ അക്കാദമിക പ്രവർത്തനങ്ങളെ ഏകോപിപ്പിച്ച് മുന്നോട്ട് നയിക്കുന്ന ഉത്തരവാദിത്തമാണല്ലോ ജില്ലാ വിദ്യാഭ്യാസ പരിശീലന കേന്ദ്രങ്ങൾ (DIET) കാലങ്ങളായി ചെയ്തുവരുന്നത്. മനുഷ്യവിഭവശേഷിയിൽ പരിമിതികൾ ഉള്ളപ്പോൾ തന്നെ പ്രീ-പ്രൈമറി തലം മുതൽ ഹയർ സെക്കൻഡറി തലം വരെയുള്ള മേഖലകളിൽ വിവിധങ്ങളായ പദ്ധതികൾ ആസൂത്രണം ചെയ്യാനും നിർവഹിക്കാനും ഡയറ്റുകൾക്ക് ഇതുവരെ കഴിഞ്ഞിട്ടുണ്ട്. പത്താം തരത്തിലെ കുട്ടികളുടെ പഠനപ്രശ്നങ്ങൾ മറികടക്കാൻ കഴിഞ്ഞ കുറച്ച് വർഷങ്ങളായി കാസറഗോഡ് ഡയറ്റ് നടപ്പിലാക്കുന്ന പദ്ധതിയാണ് **EQUIP (Educational Quality Improvement Programme)**. അതതു വർഷത്തെ കുട്ടികളുടെ പഠനപ്രശ്നങ്ങൾ പരിഗണിച്ചുകൊണ്ടാണ് പ്രവർത്തനങ്ങൾ ചിട്ടപ്പെടുത്തുന്നത്. ഈ പദ്ധതിയുടെ ഭാഗമായി പത്താംതരം പരീക്ഷയെ അഭിമുഖീകരിക്കാൻ കുട്ടികളെ സഹായിക്കുന്ന വിവിധ വിഷയബന്ധിതമായ ചോദ്യ മാതൃകകൾ പരിചയപ്പെടുത്താനാണ് ഉദ്ദേശിക്കുന്നത്. ജില്ലാ പഞ്ചായത്തിന്റെ സഹായത്തോടെ മലയാളത്തിലും ഇംഗ്ലീഷിലും കന്നഡയിലും ഏഴ് പുസ്തകങ്ങൾ (വ്യത്യസ്ത വിഷയങ്ങൾ) അച്ചടിച്ച് ഓരോ മാധ്യമത്തിലും ഓരോ കോപ്പി സ്കൂളുകളിൽ നൽകാനാണ് ഉദ്ദേശിക്കുന്നത്. ഈ അധ്യയന വർഷം പത്താംതരം പരീക്ഷ എഴുതുന്ന മുഴുവൻ കുട്ടികൾക്കും ഈ പദ്ധതിയുടെ പ്രയോജനം ലഭിക്കുമെന്ന് പ്രതീക്ഷിക്കുന്നു. വ്യത്യസ്ത പഠനവേഗതയും പഠനമികവുമുള്ള എല്ലാ വിഭാഗം കുട്ടികൾക്കും ഈ സാമഗ്രി പ്രയോജനപ്പെടട്ടെ എന്ന് ആശംസിക്കുന്നു. അധ്യാപകരുടെ ആത്മാർത്ഥമായ പിന്തുണയും പ്രോത്സാഹനവും അനിവാര്യമായ ഈ ഉദ്യമത്തിൽ എല്ലാവരുടെയും സഹായ സഹകരണങ്ങൾ പ്രതീക്ഷിച്ചുകൊണ്ട് ഏവർക്കും വിജയാശംസകൾ നേരുന്നു.

ആശംസകളോടെ,

ഡോ. രഘുരാമ ഭട്ട് കെ.

പ്രിൻസിപ്പാൾ

ഡയറ്റ് കാസർകോട്

MATHEMATICS

English Medium

EQUIP - DIET KASARAGOD
SSLC QUESTION POOL

MATHEMATICS - ENGLISH MEDIUM

1 Mark Questions

1. Which is the fifth term of the arithmetic sequence 11, 15, 19, 23,
(25, 26, 27, 28)

2.

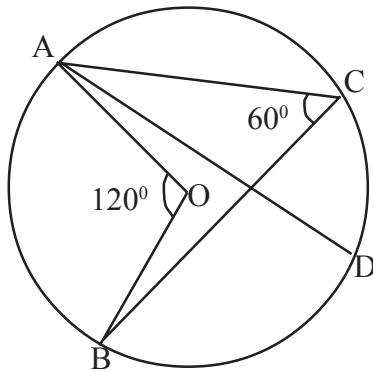

In figure $\angle AOB = 120^\circ$
 $\angle ACB = 60^\circ$
Find $\angle ADB$

(30° , 60° , 120° , 240°)

3. Numbers from 1 to 25 are written in small papers and placed in a box. A paper is taken at random, without looking. Find the probability of getting an even number.

$\left(\frac{13}{25}, \frac{12}{25}, \frac{9}{25}, \frac{11}{25}\right)$

4. In the right angled triangle ABC $\angle B = 90^\circ$, $\sin A = \frac{7}{25}$, then $\cos C = \dots\dots\dots$

$\left(\frac{7}{25}, \frac{16}{25}, \frac{9}{25}, \frac{25}{7}\right)$

5. In the figure PQ and PR are tangents through Q and R of the circle with centre O, If radius = 4 cm, $\angle QPR = 90^\circ$ then the length of PQ.....

(3, 4, 5, 6)

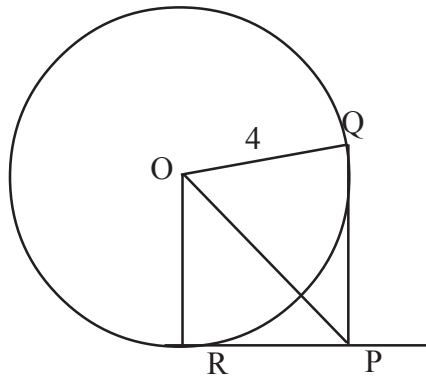

6. The slope of the line joining the points (3, 2), (8, k) is one. Find the value of K.

(5, 6, 7, 8)

7. In the figure 'O' is the centre and A,B,C are points on the circle.

$\angle OAC + \angle ABC = \dots\dots\dots$

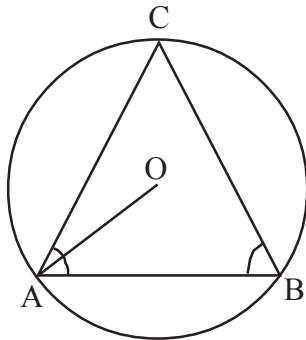

(45°, 60°, 90°, 180°)

8. Which are the two numbers whose sum is 4 and product is 2.

$(2 + \sqrt{2}, 2 - \sqrt{2}), (-2 + \sqrt{2}, 2 - \sqrt{2}),$
 $(2 + \sqrt{2}, -2 - \sqrt{2}), (2 + \sqrt{2}, 2 + \sqrt{2})$

9. What are the coordinates of the centroid of the triangle with vertices (1,2), (2,3), (3,1)?

$[(1,2), (2,2), (3,1), (1,3)]$

10. Which are the solutions of the equation $x^2 - 2x - 1 = 0$

$(1 \pm \sqrt{2}, 2 \pm \sqrt{2}, 3 \pm \sqrt{3}, 4 \pm \sqrt{3})$

11. Find the 19th term of the arithmetic sequence 18,17,16.....

(1, -1, 0, 36)

12. Name the quadrilateral for which we can always draw incircle

(Parallelogram, rectangle, trapezium, rhombus)

13. Letters of the word 'EXAMINATION' are written on different paper slip and put it in a box. One slip is taken at random. What is the probability of getting the letter 'A'?

$(\frac{1}{11}, \frac{1}{10}, \frac{2}{11}, \frac{2}{10})$

14. In $\triangle ABC$, $\sin C = \frac{AB}{BC}$ then $\cos C = \dots\dots\dots$

$(\frac{AB}{AC}, \frac{BC}{AB}, \frac{AC}{BC}, \frac{BC}{AC})$

15. In the fig. O is the centre of the circle and PQ is a tangent. Then which may be a measure of $\angle OPA$?

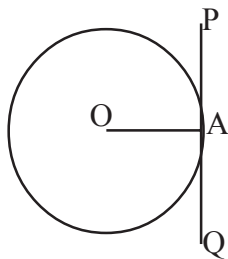

(60° , 100° , 90° , 120°)

16. A circle is drawn with the line joining the points (7,-3) and (5,5) as diameter. Then the co-ordinates of the centre is

[(12,2); (2,12); (6,1); (1,6)]

17. Which are the solutions of the second degree equation

$$3x^2 - x - 10 = 0$$

$(\left(2, \frac{5}{3}\right), \left(-2, \frac{-5}{3}\right), \left(2, \frac{-5}{3}\right), \left(-1, \frac{5}{3}\right))$

18. Equation of the circle is $x^2+y^2 = 25$. Then the centre of the circle is

- [(5,5), (5,-5), (0,0), (-5,0)]

19. Slant height and height of a square pyramid are 10 cm and 6 cm respectively. Find the length of its base edge.

- (16 cm, 8 cm, 4 cm, 2 cm)

20. Which of the following is a factor of the polynomial x^2-5x+6 .

- [(x-1), (x+2), (x-3), (x+3)]

21. The algebraic form of an arithmetic sequence is $4n-3$. What is the common difference ?

- (4,-4,3,-3)

22.

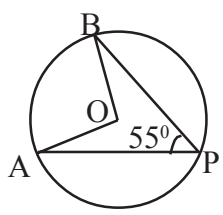

In the figure O is the centre of the circle.

If $\angle APB = 55^\circ$, What is $\angle AOB$

- (55° , 110° , 125° , $22\frac{1}{2}^\circ$)

23. In a box, there are 10 slips numbered 1,2,3.....10. If one slip is taken from the box, what is the probability of getting a prime number ?

- ($\frac{5}{10}$, $\frac{4}{10}$, $\frac{3}{10}$, $\frac{6}{10}$)

24. In triangle ABC $\angle B = 90^\circ$,

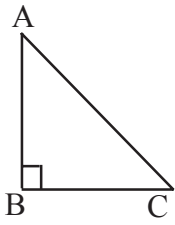

what is $\sin C = \dots\dots\dots?$

- ($\frac{AB}{BC}$, $\frac{BC}{AC}$, $\frac{AB}{AC}$, $\frac{BC}{AB}$)

25.

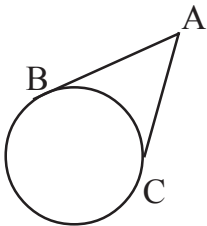

In the figure, AB and AC are tangents to the circle.

If $AB = 5\text{cm}$ What is AC ?

- ($5\sqrt{2}\text{cm}$, $5\sqrt{3}\text{cm}$, 5cm , $\frac{5}{2}\text{cm}$)

26. Find the slope of the line passing through the points (1,2) and (3,4)
(1, -1, 0, 2)
27. The solution of the equation $x^2 + 1 = 0$ is
(1, -1, 0, No solution)
28. The slant height of a square pyramid is 10 cm and its height is 8 cm. Find the base edge.
(6, 12, 10, $10\sqrt{2}$)
29. A sector of radius 16 cm and central angle 120° is rolled up into a cone. What is the slant height of the cone.
(8, 10, 16, $16\sqrt{3}$)
30. In the polynomial $P(x) = x^3 - 1$, $P(1) = 0$ write one factor of this polynomial
($x+1$, $x-1$, $x+2$, $x-2$)

2 Mark Questions

31. a) If 5th term and 8th term of an arithmetic sequence are 16 and 25 respectively then find the common difference.
b) Find the difference between 10th and 20th terms
32. In figure 'O' is the centre and A,B,C are points on the circle.
a) Find the measure of $\angle A$
b) In $\triangle BOC$, Find $\angle OBC$.

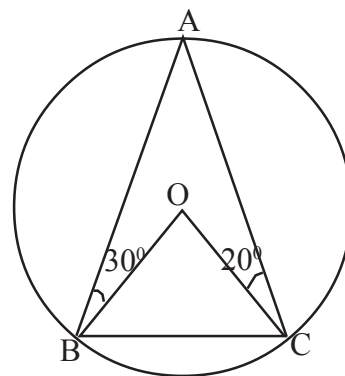

33. In figure circle exactly fitting inside a square. Calculate the probability of a dot put without looking to be within the circle.

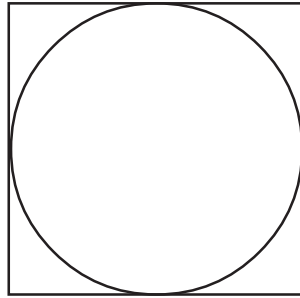

34. Coordinates of a pair of opposite vertices of a rectangle with sides parallel to the axes are $(-2,3)$ and $(5,6)$. Find the coordinates of the other vertices.

35. In an examination marks obtained by 11 students are given below.

15, 35, 20, 18, 40, 32, 28, 50, 45, 27, 31

- Find the mean mark
- Find the median mark

36. In figure 'O' is the centre of the circle and a line from the centre intersect the chord. Find the length of each part of the chord.

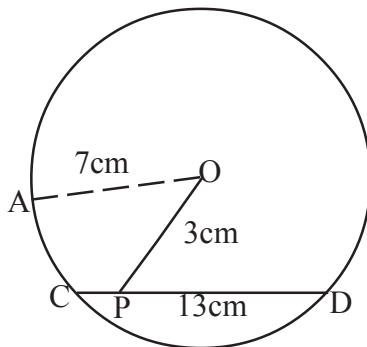

37. In figure $BC=4$ cm, $\angle B=45^\circ$, $\angle C = 75^\circ$ Find the circum radius of the $\triangle ABC$.

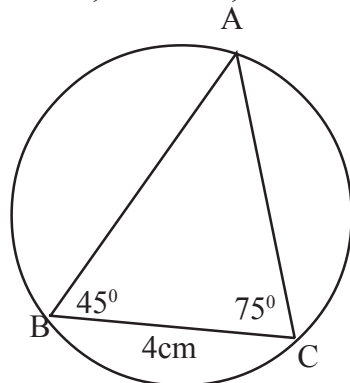

38. The perpendicular sides of a right angled triangle are 9 cm and 12 cm. Find the inradius of the triangle.

39. n^{th} term of an arithmetic sequence is given by $3n-4$.

a) Find the common difference

b) Find the 10^{th} term

40. In figure 'O' is the centre and $\angle AOD = 80^\circ$

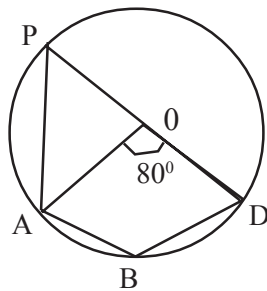

a) Find $\angle APD$

b) Find $\angle ABD$

41. A dot is put inside the circle without looking into it. Find the probability that the dot is inside the square.

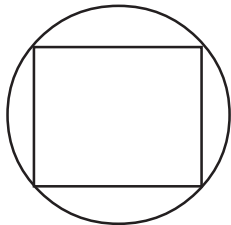

42. Draw X and Y axes and mark the following points.

a) A (0,5); B(0,-2); C(4,0); D(-3,0), E(4,5)

b) Which is not a point on axes.

43. Marks obtained by some students are given below. Find the median mark.

66, 30, 56, 20, 13, 56, 53, 70, 50, 30, 56, 45, 56

44. In $\triangle ABC$ if $\tan A = \frac{3}{4}$ then find $\sin A, \cos A$.

45. Find the inradius of an equilateral triangle of side 10 cm.
46. Base perimeter and slant height of a square pyramid are 48 cm and 10 cm respectively.
- Find the height of the pyramid
 - Find the volume.
47. a) Write the algebraic form of the arithmetic sequence 1,6,11.....
- b) Find the 15th term of this sequence

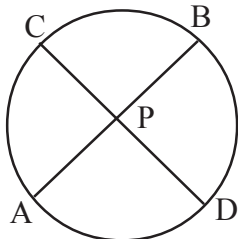
48.  In the figure $PA = 4\text{cm}$, $PB = 6\text{cm}$, $PC = 2\text{cm}$, Find PD .

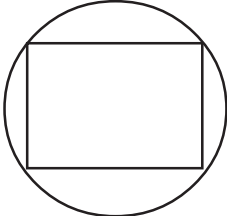
49.  A dot is put inside the circle, without looking. What is the probability that the dot is outside the square.

50. Find the co-ordinates of other two vertices of the rectangle given below.

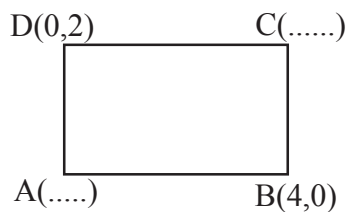

51. The weights of 25 students are given below. Find the median weight.

Weight in Kgs	No. of students
35kg	4
40kg	5
50kg	6
55kg	6
60kg	2
65kg	2

52. In triangle PQR, $\angle Q = 90^\circ$, $\sin P = \frac{7}{25}$ Find Tan P.
53. The perimeter of a triangle is 20 cm and radius of the incircle is 3 cm, find the area of the triangle.
54. The measures of one lateral face of a square pyramid are given below.
- Find the sum of all edges of the Square pyramid
 - Find the slant height.

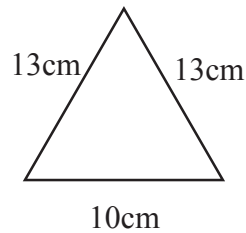

3 Mark Questions

55. Draw a rectangle of side 6 cm and 3 cm. Construct a square of equal area of the rectangle.
56. In figure AB is the diameter and CD is a chord intersecting AB at P. AB = 16 cm; CD = 19 cm, PC = 4 cm

- If $PA = x$ then find PB
- Find length of PD
- Find the length of PA

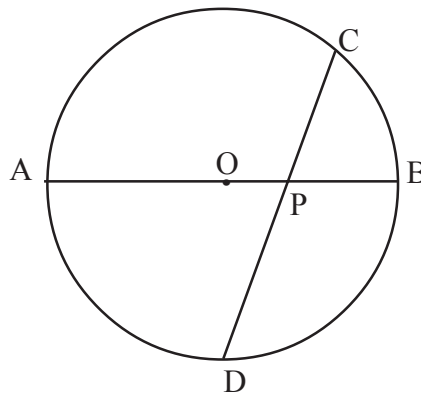

57. Draw a circle of radius 3.5 cm. Mark a point at a distance 7 cm from the centre of the circle. Draw tangents from this point to the circle. Measure the length of the tangents.

58. In figure A(4,2), B(5,4) and C(3,3) are the mid -points of the sides QR, PR and PQ of the triangle PQR respectively. Find the coordinates of the vertices of ΔPQR .

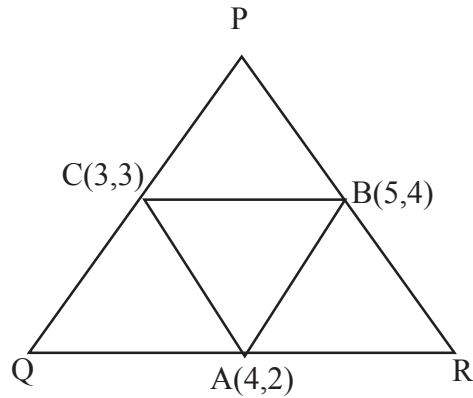

59. a) $P(x) = x^2 - 7x + 6$ Find $P(1)$, $P(6)$
b) Find the solution of the equation $P(x) = 0$
c) Write a polynomial with $P(1) = 0$, $P(2) = 0$, $P(3) = 0$
60. Sum of first n terms of an arithmetic sequence is $3n^2 + 2n$.
Find,
a) Common difference
b) prove that if 9 is added to the sum of first certain terms of the arithmetic sequence 16, 24, 32, 40, then it is a perfect square.
61. Two dice with faces numbered from 1 to 6 are rolled together.
a) What are the possible sums?
b) Which of these sums has the maximum probability?
62. Draw a rectangle of sides 4 cm and 3 cm. Construct a square of equal area.
63. 40m long wire is cut into two pieces. Each piece is bent to form squares. The sum of the area of these two squares is 58 m^2
a) If length of one piece is taken as x then find the length of other.
b) What is the length of the side of each square.
c) Form an equation with the given data
d) Find the length of each pieces.

64. Draw a circle of radius 3 cm. Draw a triangle in which sides are tangent to the circle with two of its angle 50° and 60° .

4 Mark Questions

65. Consider the line joining the points (4,5) and (7,9)
- Find the slope
 - Find two more points on the line
 - Check whether (2,2) a point on this line
 - Find the coordinate of the point of intersection of x axis and the line.
66. a) If $P(x) = x^2 - 5x + k$ $P(2) = 0$ then find the value of K
b) find the value of $P(3)$, $P(4)$
c) Check whether $(x-3)$ is a factor of $P(x)$
67. Sum of n terms of an arithmetic sequence is $3n^2 + 2n$
- Find the first term
 - Find the common difference
 - Write the sequence
 - Find the sum of first 10 term of the arithmetic sequence 7,13,19,.....
68. In class 10 A, there are 30 boys and 20 girls. In 10 B, there are 20 boys and 15 girls. One student is to be selected from each class.
- How many ways selection can be done
 - What is the probability of both being boys
 - What is the probability of both being girls
 - What is the probability of one girl and one boy.
69. Draw a rectangle with sides 5 c.m., 3 cm. construct a square of equal area.
70. In the equation $x^2 + 10x = 24$,
- What number should be added on both sides to make it a perfect square?
 - Find the values of 'x'

71. In a right triangle ABC, right angled at B, BC=12 cm, AB =5cm, What is the radius of the circle inscribed in the triangle.

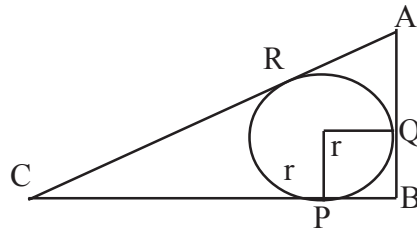

72. A(-2, -2), B(2, -2), C(0,1) are vertices of triangle ABC.
- Find the co-ordinates of the mid points of the sides of $\triangle ABC$
 - Prove that triangle ABC is an isosceles triangle.
73. Draw a circle of radius 2.5 cm. Then draw a rhombus of one angle 70° with all its sides touching the circle.
74. The sum of n terms to an arithmetic sequence is $4n^2-3n$.
Find,
- The first term
 - Find the common difference
 - Find the n^{th} term
75. In a box there are 3 black and 7 white balls. In another box, there are 4 black and 6 white balls. If One ball is taken from each box without looking into it.
- Find the probability that,
- both being black
 - both being white
 - Atleast one ball is black

5 Mark Questions

76. Length of a rectangle is 2m more than its breadth. If the area of the rectangle is 224m^2
- Take the breadth as x , find its length
 - Form a second degree equation with the given data
 - Find the perimeter of the rectangle.

77. a) In the figure AP, AQ, BC are tangents to the circle. If $AP = 12\text{ cm}$ then find the perimeter of $\triangle ABC$
- Draw a circle of radius 2.5cm .
Draw a triangle of angles $40^\circ, 60^\circ, 80^\circ$ with all its sides touching the circle.

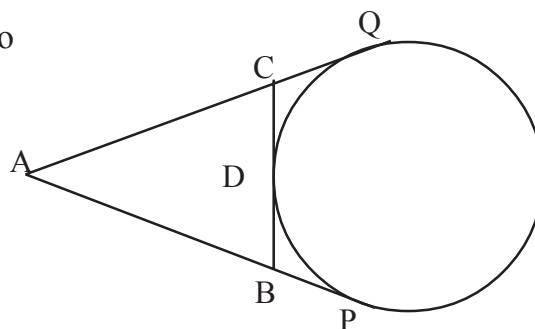

78. From the top of an electric post, two wires are stretched to either side and fixed to the ground. For one wire it makes an angle of 45° with the ground and the distance to the foot of the post is 24 metres. For the second wire it makes an angle 30° with the ground.
- Draw a rough figure
 - Find the height of the post
 - Find the total length of the wires

$$\left(\begin{array}{l} \sqrt{2} = 1.414 \\ \sqrt{3} = 1.732 \end{array} \right)$$

79. a) Prove that the points $(7,10)$; $(-2,5)$ and $(3,-4)$ are vertices of an isosceles right triangle.
- Draw X and Y axes and mark the points $A(1,1)$; $B(4,1)$; $C(4,4)$ and $D(1,4)$. Join these points in order and give a suitable name for the figure so obtained.

80. a) A square pyramid of base edge 10 cm and height 12 cm is to be made of paper. What should be the dimensions of the triangles.
- b) The height of a square pyramid with all its edges are equal is 12 cm. Find its volume.
81. a) Find the coordinates of the points which divides the line joining the points (1,2) and (7,5) into three equal parts.
- b) Find the equation of the circle in the given figure.

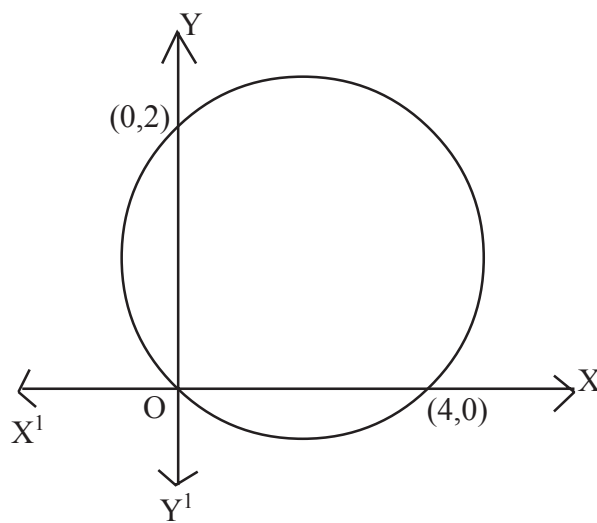

82. The table below shows the ages of 100 people.

a)

Age	Number of people
0-10	5
10-20	15
20-30	20
30-40	25
40-50	15
50-60	11
60-70	9
Total	100

- a) The age of the persons at what position is taken as the median.
 b) What is the assumed age of 41th person?
 c) Find the median age.
83. In a right triangle one of the perpendicular side is one less than two times the shortest side. Hypotenuse is one more than two times the shortest side.
- a) Considering the shortest side as x , find the other two sides.
 b) Find the sides of triangle
 c) Find the area of the triangle.
84. Two buildings are 24 m apart. From the top of the smaller building, one sees the foot of the taller building at a depression of 60° and its top at an elevation of 30° .
- a) Draw a rough figure
 b) Find the heights of both buildings.
85. In the figure the coordinates of 3 vertices of a square are given.

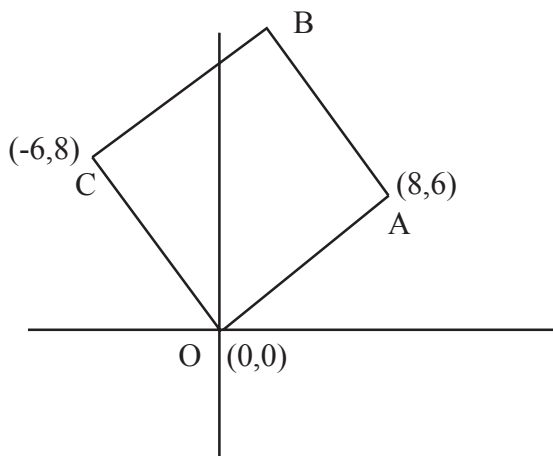

- a) Find the coordinates of the fourth vertex
 b) Find the length of its side
 c) Find the area.
86. a) In figure O is the centre of the circle and PA is a tangent.
 If $PA = 5$ cm and $OP = 4$ cm then find the radius of the circle.

- b) Draw a circle of radius 3 cm. Draw tangent from a point which is at a distance of 4 cm away from the centre of the circle. Measure the length of the tangent.

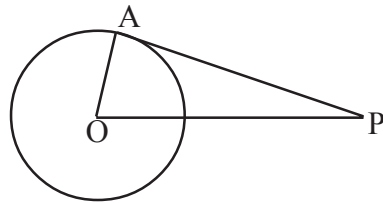

87. Draw a rectangle of sides 6 cm and 4 cm. Draw another rectangle with one side 7 cm and area equal to that of the first rectangle.

88. a) In the figure below find the coordinate of the centre of the circle.
 b) Find the radius.
 c) Find the equation of the circle.

- d) Find the centre of the circle with equation.

$$x^2+4x+y^2 - 6y+12 = 0$$

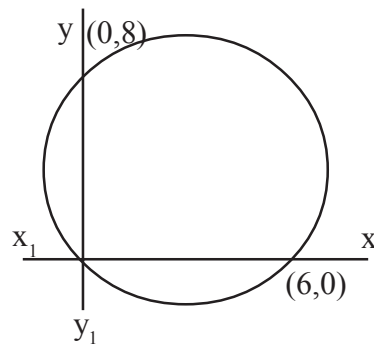

89. In a locality the house are classified according to the consumption of electricity.

Consumption of Electricity	Number of House
0-60	4
60-120	10
120-180	12
180-240	15
240-300	14
300-360	4

- a) Find the total number of houses
 b) According to the hypothesis what is the consumption of electricity of 27th house.
 c) Find the median

90. The length of a rectangle is 4 cm more than its breadth ; the area of that rectangle is 96cm^2

- If the breadth is 'x' find the length.
- Find the length and breadth of the traingle.

91.

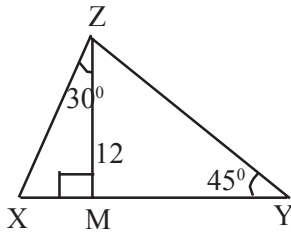

In the figure $MZ=12\text{ cm}$, $\angle MZX = 30^\circ$
 $\angle Y=45^\circ$ and ZM is Perpendicular to XY

- Find MX, XY
- Find the perimeter of ΔXYZ
- Find $XZ : YZ : XY$

92. In the figure ΔABC is an equilateral one .

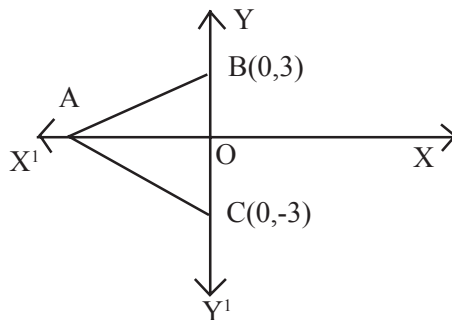

- Find the length of one side of triangle ABC.
- Find the perimeter of triangle ABC
- Find the co-ordinates of A.

93. In triangle ABC $\angle A = 60^\circ$, $\angle B = 50^\circ$, $AR = 3\text{cm}$,

$CQ = 4\text{cm}$, $BQ = 5\text{cm}$

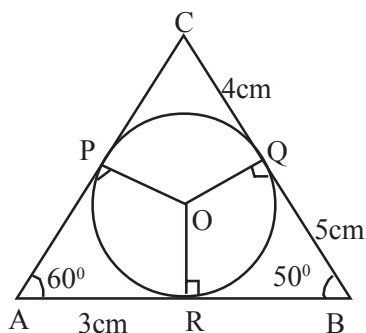

- Find the perimeter of ΔABC
- Find $\angle POR, \angle POQ$
- Find $\angle RPQ, \angle BRQ$

94. Draw a rectangle with sides 6 cm and 4 cm.

Draw another rectangle of same area with one side 7 cm.

95. In the figure, the radius of the circle is 5 cm. Centre is the origin.

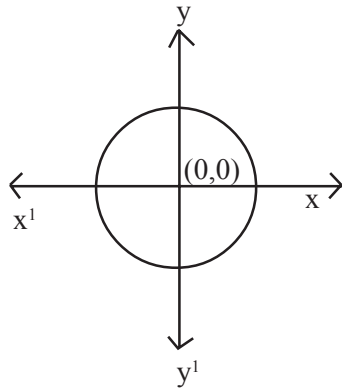

- Find the co-ordinates of the points of intersection of the circle with the X and Y axes.
- Write the equation of the circle.
- Find the Co-ordinates of any other two points on the circle.

96. The details of income tax given by the teachers of a school is given below.

a)

Income tax in rupees	Number of Teachers
30,000 - 40,000	4
40,000 - 50,000	6
50,000 - 60,000	5
60,000 - 70,000	4
70,000 - 80,000	4

- The income tax of the teachers at what position is taken as the median ?
- What is the assumed income tax of 11th teacher?
- Find the median tax.

97. Consider the pattern

1
 2 3 4
 5 6 7 8 9
 10 11 12 13 14 15 16

- a) Write the next line
- b) Write the sequence of number of numbers in each row.
- c) Write the algebraic form of the sequence 1,3,5,7.....
- d) How many numbers are there in 30th row
- e) Write the first and last number in the 30th row.

98. a) A sector of a circle with radius 18 cm and central angle 240° is bent to form a cone.

- i) Find the slant height of the cone
- ii) Find the base radius of the cone
- iii) Find the curved surface area.

b) Consider a cone of height and radius equal, a hemisphere, a cylinder of equal radius and height and a sphere. Radius of each figures is 'r' unit. Prove that the volumes of these are in arithmetic sequence.

99. Read the following and understand the mathematical idea expressed in it and answer the questions that follows.

1,4,9,16....are the squares of the counting numbers. The remainders got by dividing the square numbers with natural numbers have a cyclic property. For example the remainders on dividing these numbers by 3 are tabulated here

Number	1	4	9	16	25	36	49
Remainder	1	1	0	1	1	0	1

- a) Write the 8th term of the sequence 1, 4, 9, 16.....
- b) What is the remainder when 100 is divided by 3
- c) Which are the possible remainders when a perfect square is divided by 3
- d) Find the remainder when the numbers of the sequence $5^2, 8^2, 11^2, \dots$ are divided by 3.
- e) What is the remainder that leaves on dividing the terms of the sequence $4^2, 7^2, 10^2, \dots$ by 3.
100. The sum of first nine terms of an arithmetic sequence is 261 and sum of next 6 terms is 444.
- a) Find 5th and 8th term
- b) Find the first term and common difference
- c) Write the sequence
- d) Write the algebraic expression of the arithmetic sequence
- e) Find the sum of first 15 terms of the arithmetic sequence 6,12,18.....
101. Height and radius of a conical vessel are 8cm and 5 cm respectively. It is completely filled with water. Some lead balls of radius 0.5cm were immersed in it. One fourth of water spilled out. Find the number of balls immersed.
102. Read the mathematical concept carefully and answer the following.

$$1 = 1$$

$$1+2 = 3$$

$$1+2+3 = 6$$

$$1+2+3+4=10$$

Consider the sequence 1,3,6,10.....

It is the sum of natural numbers. These numbers are called triangle numbers.

$$1+3 = 4 ; 3+6 = 9, 6+10 = 16 \dots\dots\dots$$

1, 4, 9, 16, are called square numbers. Each square number is the sum of two consecutive triangle numbers.

- a) Find the next term of the sequence 1,3,6,10.....
- b) Find the fifth square number
- c) Write the algebraic form of the sequence of triangle numbers
- d) Write the algebraic expression of the sequence of square numbers.
- e) If 20th triangle number is x and 21st triangle number is y then $y-x = \dots\dots\dots$

103.

1
 3 5 7
 9 11 13 15 17

.....

- a) Write the next two lines of this pattern
- b) How many numbers are there in 10th row.
- c) Find the sum of all numbers in the 10th row..
- d) Write the algebraic form of the arithmetic sequence 1, 3, 5, 7,

104.

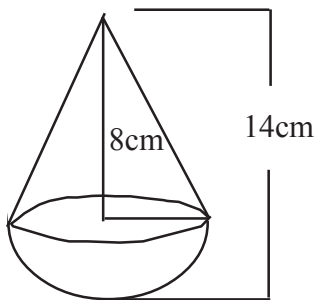

A toy is made in the form of a cone mounted on a hemisphere.

The total length of the toy is 14 cm and height of the cone alone is 8 cm.

- a) Find the radius of the hemisphere ?
- b) Find the total surface area of the toy.
- c) Find the total cost of painting 500 such toys at the rate of Rs. 2 per square centimeter.

EQUIP - DIET KASARAGOD
SSLC QUESTION POOL

MATHEMATICS - ENGLISH MEDIUM

1 Marks Questions - Answers

1. 27 (1)
2. 60° (1)
3. $\frac{9}{25}$ (1)
4. $\frac{7}{25}$ (1)
5. 4 (1)
6. 7 (1)
7. 90° (1)
8. $2 + \sqrt{2}, 2 - \sqrt{2}$, (1)
9. (2,2) (1)
10. $1 \pm \sqrt{2}$ (1)
11. 0 (1)
12. rhombus (1)
13. $\frac{2}{11}$ (1)
14. $\frac{AC}{BC}$ (1)
15. 60° (1)
16. (6,1) (1)
17. $\left(2, \frac{-5}{3}\right)$ (1)
18. (0,0) (1)
19. 16cm (1)
20. (x-3) (1)

21. 4 (1)
22. 110° (1)
23. $\frac{4}{10}$ (1)
24. $\frac{AB}{AC}$ (1)
25. $AC = 5\text{cm}$ (1)
26. 1 (1)
27. No Solution (1)
28. 12cm (1)
29. 16cm (1)
30. $x-1$ is a factor (1)

2 Marks Questions - Answers

31. a) $d=3$ (1)
 b) 30 (1)
32. a) $\angle A=50^\circ$ (1)
 b) $\angle OBC = 40^\circ$ (1)
33. $\frac{\pi}{4}$ (2)
34. $(-2,6), (6,3)$ (1+1=2)
35. a) Mean = 31 (1)
 b) Median = 31 (1)
36. 8, 5 (2)
37. $\frac{a}{\sin A} = 2R \Rightarrow A = 60$ (2)
- $a=4 \quad \sin A = \frac{\sqrt{3}}{2} \quad \frac{a}{\sin A} = \frac{4}{\frac{\sqrt{3}}{2}} = \frac{8}{\sqrt{3}}$ (2)

$$38. \quad r = \frac{A}{S} \quad A = 54, \quad S = 18 \quad (1)$$

$$r = 3$$

$$39. \quad \text{a) } 3 \quad (1)$$

$$\text{b) } 26, 3 \times 10^{-4}$$

$$= 30 - 4$$

$$= 26 \quad (1)$$

$$40. \quad \text{a) } \angle APD = \frac{80}{2} \quad (1)$$

$$= 40$$

$$\text{b) } \angle ABD = 180 - 40$$

$$= 140 \quad (1)$$

41.

radius of the circle r

diameter of circle = diagonal of square

$$\text{probability} = \frac{(2r)^2}{\pi r^2} = \frac{2r^2}{\pi r^2} = \frac{2}{\pi} \quad (2)$$

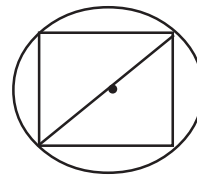

$$42. \quad \text{a) for drawing X, Y axes and marking the points.} \quad (1)$$

$$\text{b) E or (4,5)} \quad (1)$$

$$43. \quad \text{Arranging in ascending or descending order} \quad (1)$$

13, 20, 30, 30, 45, 50, 53, 56, 56, 56, 56, 66, 70

$$\text{Median} = 53 \quad (1)$$

$$44. \quad \sin A = \frac{3}{5} \quad (1)$$

$$\cos A = \frac{4}{5} \quad (1)$$

$$45. \quad r = \frac{A}{S}$$

$$A = \frac{\sqrt{3}}{4} \times 10 \times 10 \quad (1)$$

$$S = 15$$

$$r = \frac{\sqrt{3} \times 10 \times 10}{4 \times 15}$$

$$= \frac{5}{\sqrt{3}} \quad (1)$$

46. Area of triangle = $\frac{48}{4}$

$$= 12$$

a) height = 8 (1)

b) Volume = $\frac{1}{3} \times 12^2 \times 8$

$$= 384 \text{cm}^3 \quad (1)$$

47. a) $x_n = 5n - 4$ (1)

b) $x_{15} = 5 \times 15 - 4 = 71$ (1)

48. PA x PB = PC x PD

$$4 \times 6 = 2 \times \text{PD} \quad (2)$$

$$\therefore \text{PD} = \frac{4 \times 6}{2} = 12$$

49.

$$1 - \frac{2}{\pi} \quad (2)$$

50. A (0,0) C(4,2) (1)

51. Median Weight = $\frac{25+1}{2}$ = Weight of 13th student = 50kg (2)

52.

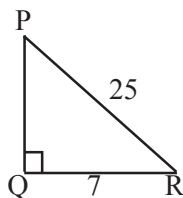

$$PQ = \sqrt{25^2 - 7^2} = \sqrt{625 - 49} \quad (1)$$

$$= \sqrt{576} = 24 \text{cm} \quad (1)$$

$$\tan P = \frac{7}{24}$$

53. Area = $rs = 3 \times \frac{20}{2} = 10\text{cm}^2$ (2)

54. a) $4 \times 13 + 4 \times 10$
 $= 52 + 40 = 92\text{cm}$ (1)

b) $\sqrt{13^2 - 5^2} = \sqrt{169 - 25} = \sqrt{144} = 12\text{cm}$ (1)

3 Marks Questions - Answers

55. For correct figure (3)

56. a) $16 - x$ (1)

b) $PD = 15$ (1)

c) $PA = 10$ (1)

57. For correct figure (3)

58. By considering the parallelograms QABC, ARBC, and ABPC

$$P = (4,5) \quad Q = (2,1) \quad R = (6,3) \quad (3)$$

59. a) $P(1) = 6$ (1)

$$P(6) = 0$$

b) 1, 6 (1)

c) $(x-1) (x-2) (x-3)$ (1)

60. a) $d=6$ (1)

b) $S_n = 4n^2 + 12n$

$$S_{n+9} = 4n^2 + 12n + 9$$

$$= (2n+3)^2 \quad (2)$$

61. a) 2, 3, 4, 5, 6, 7,
8, 9, 10, 11, 12 (2)

b) 7 (1)

62. For drawing rectangle (1)

for drawing square (2)

63. a) $40 - x$

b) $\frac{x}{4}, \frac{40-x}{4}$ (1)

c) $\left(\frac{x}{4}\right)^2 + \left(\frac{40-x}{4}\right)^2 = 58$ (1)

d) 28, 12 cm (!)

4 Mark Questions - Answers

64. For drawing the circle with radius 4 (1)

For drawing triangle (2)

65. a) Slope = $\frac{4}{3}$ (1)

b) (10, 13), (13, 17) (2)

c) $\frac{2-9}{2-7} = \frac{-7}{-5} = \frac{7}{5}$

not a point. (1)

d) Point on x axis (x,0)

$$\text{Slope} = \frac{5-0}{4-x} = \frac{4}{3}$$

$$\frac{5}{4-x} = \frac{4}{3}$$

$$15 = 16 - 4x$$

$$4x = 16 - 15$$

$$= 1$$

$$x = \frac{1}{4}$$

$$\text{point} = \left(\frac{1}{4}, 0\right) \quad (1)$$

66. a) $2^2 - 5x^2 + k = 0$

$$-6 + k = 0$$

- k = 6 (1)
- b) $P(3) = 0$ (1)
- $P(4) = 4^2 - 20 + 6$
- $= 2$ (1)
- c) $P(3) = 0$
- \therefore a factor (1)
67. a) 5 (1)
- b) 6 (1)
- c) 5, 11, 17..... (1)
- d) $320 + 20 = 340$ (1)
68. a) $50 \times 35 = 1750$ (1)
- b) $\frac{600}{1750}$ (1)
- c) $\frac{300}{1750}$ (1)
- d) $\frac{850}{1750}$ (1)
69. To draw the square with specific measures (4)
- 70 a) $5^2 = 25$
- b) $x^2 + 10x + 25 = 24 + 25 = 49$
- ie $(x+5)^2 = 7^2$ (2)
- | | |
|-------------|----------------|
| $x+5 = 7$ | $x+5 = -7$ |
| $x=7-5 = 2$ | $x=-7-5 = -12$ |
- (2)

71.

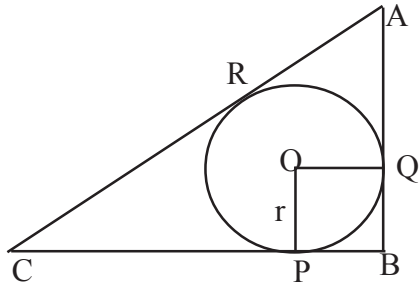

$$AC^2 = 12^2 + 5^2 = 13^2$$

$$AC = 13$$

$$CP = 12 - r$$

$$CR = 12 - r$$

$$AR = AQ = 5 - r$$

$$12 - r + 5 - r = 13$$

$$17 - 2r = 13$$

$$r = \frac{17 - 13}{2} = \frac{4}{2} = 2$$

(4)

72.

a)

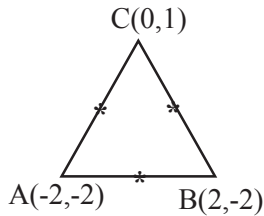

$$\begin{aligned} \text{Mid-point of AB} &= \left(\frac{-2+2}{2}, \frac{-2+-2}{2} \right) \\ &= (0, -2) \end{aligned}$$

$$\begin{aligned} \text{Mid-point of BC} &= \left(\frac{2+0}{2}, \frac{-2+1}{2} \right) \\ &= (1, -\frac{1}{2}) \end{aligned}$$

$$\begin{aligned} \text{Mid-point of AC} &= \left(\frac{-2+0}{2}, \frac{-2+1}{2} \right) \\ &= (1, -\frac{1}{2}) \end{aligned}$$

(3)

b) $AC^2 = 2^2 + 3^2 = 13$

$$BC^2 = 2^2 + 3^2 = 13$$

$$\therefore AC = BC$$

$$\therefore \text{Isosceles}$$

(1)

73. Draw the rhombus with the specific measures.

(4)

74.

a) 1

(1)

b) 8

(1)

c) $8n - 7$

(2)

75. a) $\frac{3 \times 4}{10 \times 10} = \frac{12}{100}$ (1)

b) $\frac{7 \times 6}{10 \times 10} = \frac{42}{100}$ (1)

c) 1 - P (Both are black)

$$= 1 - \frac{12}{100} = \frac{88}{100} \quad (2)$$

5 Marks Questions - Answers

76. a) $x+2$ (1)

b) $x^2+2x=224$ (2)

c) $l = 16, b = 14$

Perimeter = 60 (2)

77. a) 24 (2)

b) For correct figure (3)

78. a)

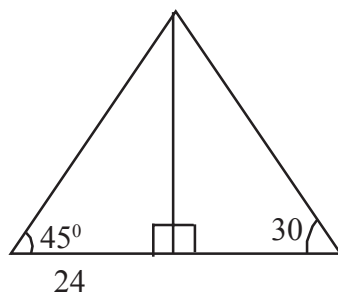

(1)

b) 24 m (2)

c) $48 + 24\sqrt{2}$ (2)

79. a) $AB = \sqrt{212}$

$BC = \sqrt{106}$

$AC = \sqrt{106}$

$AB^2 = BC^2 + AC^2$ (3)

b) Square (2)

80. a)

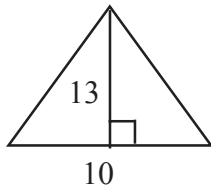

Triangle with base 10 and height 13cm

or

Sides are $\sqrt{194}$ cm; $\sqrt{194}$ cm and 10cm (3)

b) $h=12$, $a=e$

$$a = 12\sqrt{2}$$

$$r = \frac{1}{3}a^2h$$

$$= \frac{1}{3} \times 12\sqrt{2} \times 12\sqrt{2} \times 12 \quad (3)$$

$$= 1152\text{cm}^3$$

81.

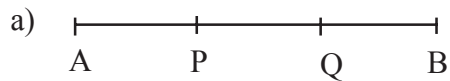

$$AP : PB = 1:2$$

\therefore P is (3,3) (2)

$$PQ + QB = 1:1$$

Q is (5,4) (1)

b) $(x-2)^2 + (y-1)^2 = 5$ (2)

82.

Age	Number
below 10	5
below 20	20
below 30	40
below 40	65
below 50	80
below 60	91
below 70	100

10

(1)

a) 50, 51 (1)

b) $30 + \frac{5}{25} = 30.2$ (1)

c) Median = $\frac{50^{th} + 51^{st}}{2}$
 $= 30 \frac{100}{25}$
 $= 30 + 4 = 34$ (2)

83. a) $2x-1, 2x+1$ (1)

b) $x^2 + (2x-1)^2 = (2x+1)^2$ (1)

$x^2 + 4x^2 - 4x + 1 = 4x^2 + 4x + 1$

$x^2 - 8x = 0$ (1)

$x(x-8) = 0 \quad x=8$ (1)

Sides 8cm, 15cm, 17cm (1)

84.

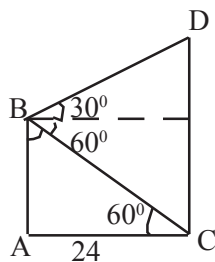

(1)

Height of the small building = $24\sqrt{3}$ (2)

Height of taller building

$= \frac{24}{\sqrt{3}} + 24\sqrt{3}$

$= 8\sqrt{3} + 24\sqrt{3}$

$= 32\sqrt{3}$ (3)

85. a) (2,14) (2)

b) $\sqrt{8^2 + 6^2} = 10$ unit (1)

c) $10 \times 10 = 100$ square unit (2)

86. a) $\text{radius}^2 = 5^2 - 4^2$
 $= 9$
radius = 3 (2)
For drawing the figure (2)
Length = 5cm (1)
87. For drawing rectangle of sides 6, 4 (1)
Drawing another rectangle with one side 7 (4)
88. a) (3, 4) (1)
b) 5 unit (1)
c) $(x-3)^2 + (y-4)^2 - 25$ (1)
d) (-2,3) (2)
89.

60	4
120	14
180	26
240	41
300	55
360	59
- a) 59 (1)
b) 182 (2)
c) 194 (2)
90. a) $x+4$ (1)
b) $x(x+4) = 96$
 $x^2 + 4x = 96$
 $x^2 + 4x + 2^2 = 22+96$
 $(x+2)^2 = 100 = 10^2$

$x+2 = 10$	breadth = 8cm
$x=10-2=8$	length = 12cm

 (4)

91. a) $MX = \frac{12}{\sqrt{3}}, XY = \frac{12}{\sqrt{3}} + 12$ (1)

b) Perimeter = $XY + YZ + ZX$

$$= \frac{24}{\sqrt{3}} + 12\sqrt{2} + \frac{12}{\sqrt{3}} + 12$$
 (2)

$$\frac{36}{\sqrt{3}} + 12\sqrt{2} + 12$$

c) $2 : \sqrt{6} : \sqrt{3} + 1$ (2)

92. a) 6cm (1)

b) 18cm (2)

c) A is $(-3\sqrt{3}, 0)$ (2)

93. a) $AB + BC + AC$
 $= 8 + 9 + 7 = 24\text{cm}$ (1)

b) $\angle PQR = 120^\circ, \angle POQ = 110^\circ$ (2)

c) $\angle RPQ = 65^\circ, \angle BRQ = 65^\circ$ (2)

94. Draw the rectangle. Draw a rectangle of the same area. (5)

95. a) $(5,0) (-5,0) (0,5) (0,-5)$ (2)

b) $x^2 + y^2 = 25$ (1)

c) $(3,4) (-3,4)$ (2)

96. a) $\frac{23+1}{2} = \text{Tax of } 12^{\text{th}} \text{ teacher}$ (1)

b) Assumed tax for 11^{th} teacher.

$$d = \frac{10000}{5} = 2000$$

$$= 50000 + \frac{d}{2}$$

$$= 50000 + 1000$$

$$= 51000$$
 (2)

c) Median Tax = $51000 + 2000$

$$\mathbf{53,000}$$
 (2)

97. a) 17 18 19 20 21 22 23 24 25 (1)
- b) 1, 3, 5, 7, (1)
- c) $x_n = 2n-1$ (1)
- d) $x_{30} = 59$ (1)
- e) $30^2 = 900$ (last number) (1)
- First Number = 842 (2)

- 98 a) (i) 18cm (1)
- ii) $r = 12$ cm (1)
- iii) 216π cm² (1)
- b) $\frac{1}{3}\pi r^3$, $\frac{2}{3}\pi r^3$, πr^3 , $\frac{4}{3}\pi r^3$ (1)
- $d = \frac{1}{3}\pi r^3$ (2)

99. a) 64 (1)
- b) 1 (1)
- c) 0, 1 (1)
- d) 1 (1)
- e) 1 (1)

100. a) 5th term = $\frac{261}{9} = 29$ (1)

8th term = $\frac{261+444}{15}$

= $\frac{705}{15} = 47$ (1)

b) $d = \frac{47-29}{8-5} = \frac{18}{3} = 6$

$f = 29-24 = 5$ (1)

$$c) 6n-1 \quad (1)$$

$$d) 705 + 15 = 720 \quad (2)$$

101. Volume of the cone

$$= \frac{1}{3} \times \pi \times 5 \times 5 \times 8 \quad (1)$$

$$\text{Volume of sphere} = \frac{1}{4} \left(\frac{1}{3} \times \pi \times 5 \times 5 \times 8 \right)$$

$$= \frac{1}{4} \times \pi \times \frac{5}{10} \times \frac{5}{10} \times \frac{5}{10} \quad (2)$$

$$n = \frac{4}{3} \times \pi \times \frac{5}{10} \times \frac{5}{10} \times \frac{5}{10} = \frac{1}{12} \times \pi \times 5 \times 5 \times 8$$

$$n = 100 \quad (2)$$

102. a) 15 (1)

b) 25 (1)

c) $n \left(\frac{n+1}{2} \right)$ (1)

d) n^2 (1)

e) 21 (1)

103. a) 19, 21, 23, 25, 27, 29, 31
33, 35, 37, 39, 41, 43, 45, 47, 49 (1)

b) $x_n = 2n-1$
 $x_{10} = 2 \times 10 - 1 = 19$ (1)

c) $\frac{19}{2} (163 + 199) = 19 \times 181 = 3439$ (2)

d) $2n-1$ (1)

104. a) 6cm (1)

b) $132 \times 3.14 \text{ cm}^2$
 $= 2\pi r^2 + \pi r h$
 $= 72\pi + 60\pi = 132\pi \text{ cm}^2$
 $= 132 \times 3.14 \text{ cm}^2$
 $= 414.48 \text{ cm}^2$ (2)

c) $414.48 \times 2 \times 500$
 $= 828.96 \times 500 \text{ rupees}$ (2)
 $= \mathbf{414,480}$ rupees





DISTRICT PANCHAYATH KASARAGOD



DIET KASARAGOD