

GEOMETRICAL AND MECHANICAL DRAWING (869)

This subject may not be taken with Geometrical and Building Drawing

Candidates will be required to reach a minimum standard in the subject as a whole. The use of drawing board, tee-square and set-square will be required. (Candidates may, if they wish, use a drawing board fitted with a parallel motion straight

edge. The use of drafting machines will be permitted). A2 size paper will be used. The recommendation of IS:696-1972 Indian Standard, Code of Practice for General Engineering Drawing should be followed.

CLASS XI

There will be two papers in the subject:

Paper I - Theory: 3 hours..... 80 Marks

Paper II - Project Work 20 Marks

PAPER I (THEORY): 80 MARKS

SECTION A

Plane Geometry

Construction and use of scales including diagonal scales. Enlargement and reduction of irregular plane figures. Construction of triangles, quadrilaterals and polygons. Similar plane figures. Problems on circles, tangents and normals. Loci such as the paths of points in simple link mechanisms. Methods of construction of ellipse, including its elementary properties, parabola and rectangular hyperbola; cycloidal and involute curves.

SECTION B

Solid Geometry

Orthographic projection. (Diagrams printed in the question papers may be in either First or Third Angle projections; the projection used will be stated. Solutions in either First or Third Angle projections will be accepted). Projection involving use of auxiliary planes; simple problems on auxiliary projection. Simple problems on the intersection of prisms, pyramids, cylinders, right circular cones, and spheres. Determination of true length of a line in space: sections and surface development of prisms, pyramids, cylinders and right circular cones. Helix treated as a locus with applications on the projection of helices. Isometric and oblique projection without the use of isometric scale.

PAPER II (PROJECT WORK): 20 Marks

In addition to the syllabus prescribed above, candidates are also required to be assessed in Project Work. The Project work will be assessed by the subject teacher.

All candidates will be required to attempt either Drawing A or Drawing B from each of the three project sheets given. **Each** drawing will carry **5 Marks**.

Mark allocation for each Drawing (5 marks):

Criteria		Marks
1.	Project size / completeness	1
2.	Line Quality	1
3.	Neatness	1
4.	Accuracy	1
5.	Title Block	1
TOTAL		5

Marks out of 20 will be distributed as given below:

1.	3 Drawings × 5 Marks	15 Marks
2.	Viva-Voce by the subject teacher	5 Marks
TOTAL		20 Marks

Instructions for Project Work:

- Candidates must use A2 size (**Half Imperial**) drawing sheets to complete all projects. A sample project sheet layout with specifications, is given below:

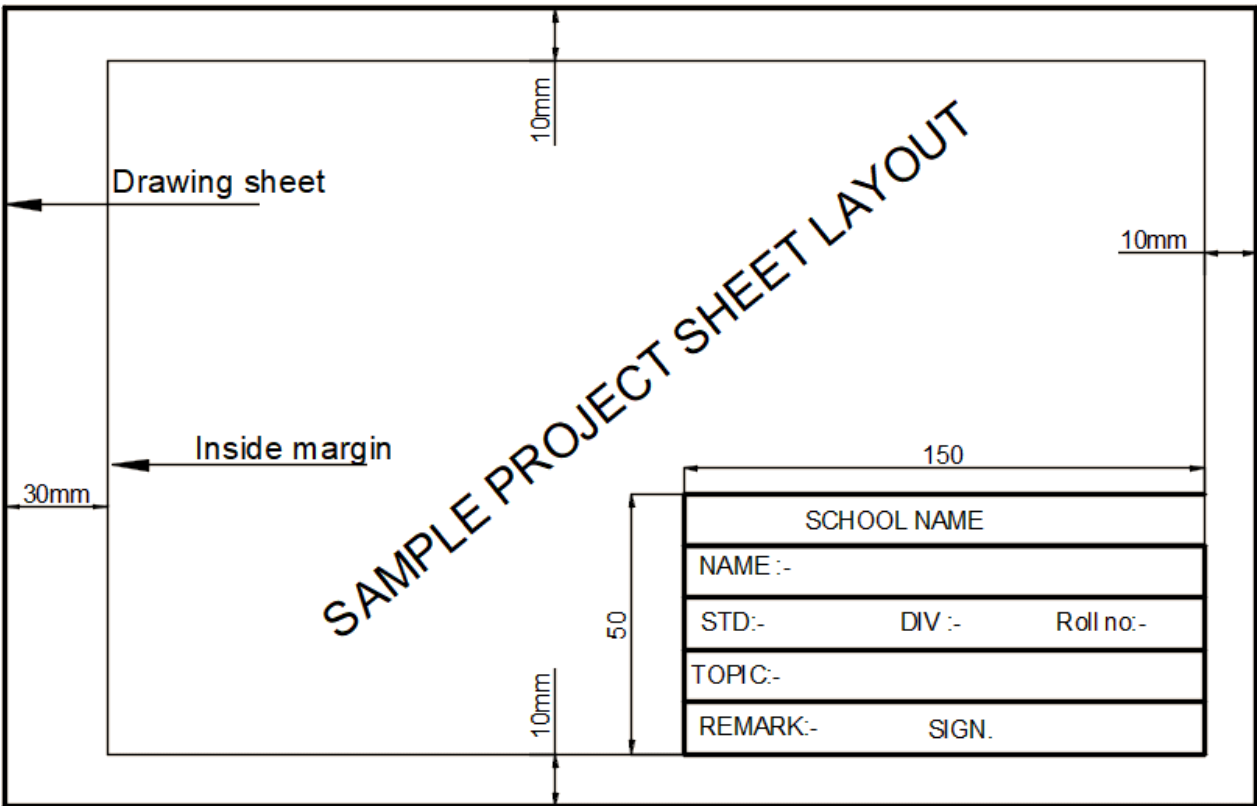

- Candidates must use the given layout and specifications to complete each project sheet.
- Accuracy, neat and clean work is expected from candidates.
- Candidates need **not** draw / paste the questions.

PROJECT SHEETS

Candidates will be required to attempt either Drawing A or Drawing B from each of the three project sheets given below.

Project Sheet 1

Draw by using 1st OR 3rd angle method of projection i) F.V, ii) T.V. & iii) L.H.S.V

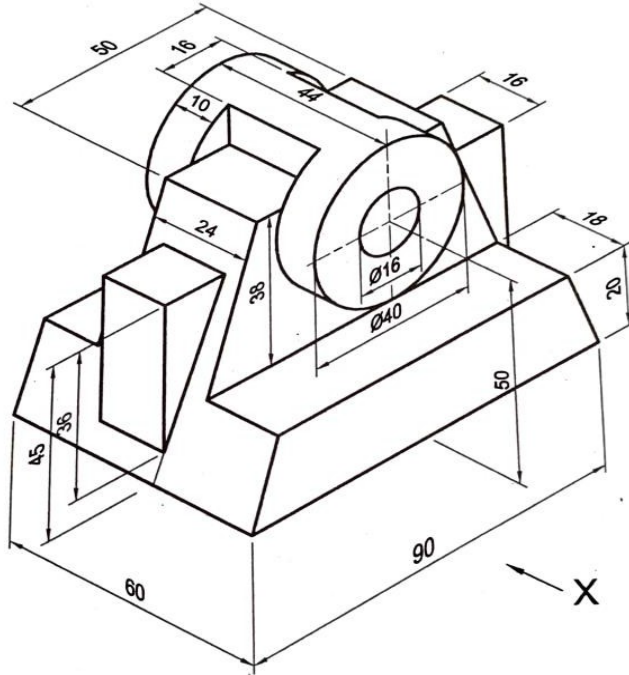

OR

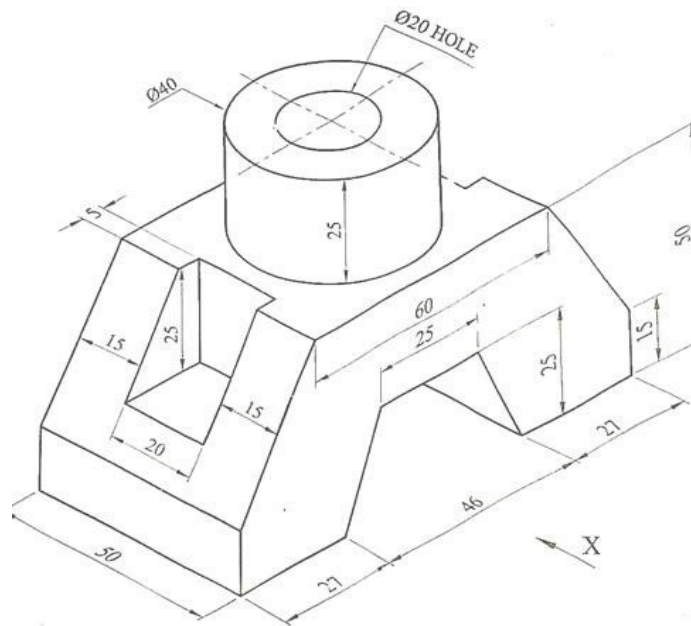

Project Sheet 3

Draw an isometric view of a given object.

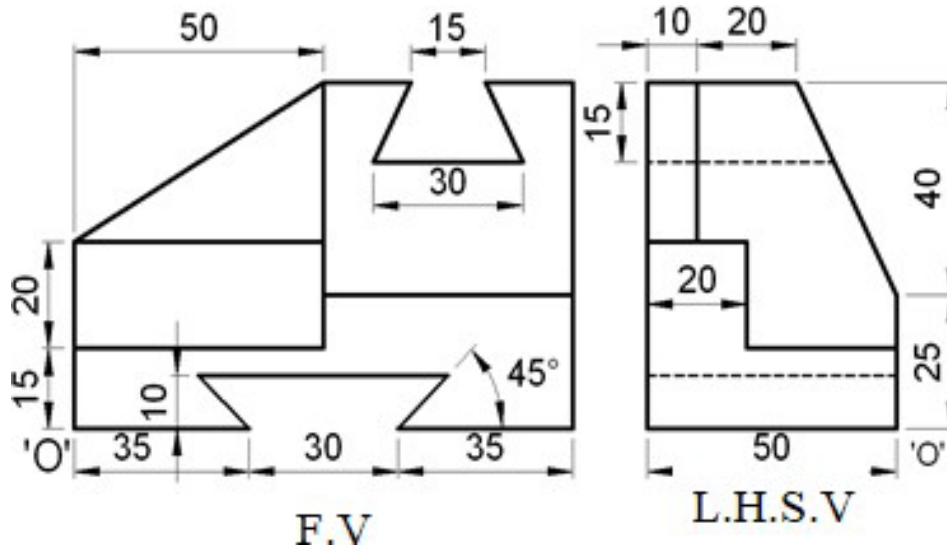

OR

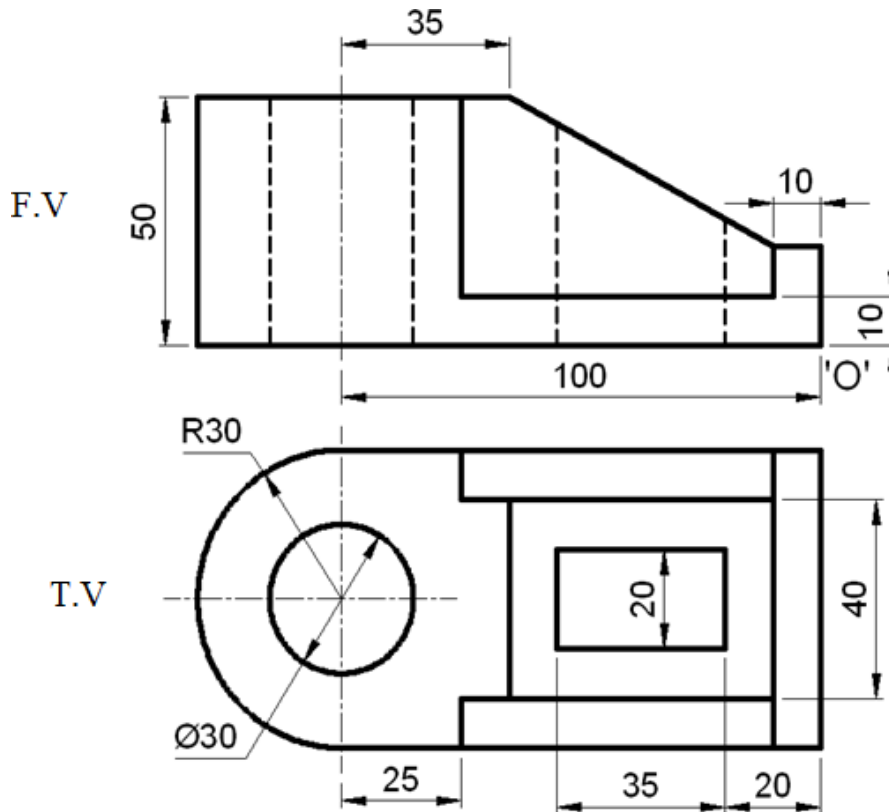

CLASS XII

There will be two papers in the subject:

Paper I - Theory: 3 hours..... 80 Marks

Paper II - Project Work 20 Marks

PAPER I (THEORY): 80 MARKS

Drawing (Engineering)

Candidates will be required to answer **all** questions.

The preparation of working drawings and assemblies from dimensioned sketches based on the following:

- (a) fastening (nuts, bolts, studs, keys, cotters, pins, locking devices);
- (b) rigid and flexible joints;
- (c) screw threads; their projection and the proportions of standard types, profiles and proportions of spur gear teeth; conventional methods of drawing gear wheels;
- (d) transmission of motion and power, bearings, supports, shafts, coupling and clutches;
- (e) pressure transmission in pipes using water, oil, steam and gas, joints, unions, tees and bends, expansion joints, pressure packing;
- (f) constructional details of prime moves and simple machine tools;
- (g) the use of reference points and planes in dimensioning, machining and surface texture symbols;
- (h) toleranced dimensions involving the use of IS:919 or B.S. 4500 Limits and Fits for Engineering.

Candidates will be expected to follow the recommendations given in IS:696 - 1972 Indian Standard, Code of Practice for General Engineering Drawing. They should be familiar with both First and Third Angle projections.

PAPER II (PROJECT WORK): 20 Marks

In addition to the syllabus prescribed above, candidates are also required to be assessed in Project Work.

All candidates will be required to have completed **three** project sheets, selecting at least **one** from Section A (Orthographic Projections) and **one** from Section B (Assembly Drawings). **Each** Project sheet will carry **5 Marks**.

The Project work will be assessed by the subject teacher and the Visiting Examiner appointed locally and approved by CISCE.

Mark allocation for each Project sheet (5 marks)*:

Criteria		Marks
1.	Project size / completeness	1
2.	Line Quality	1
3.	Neatness	1
4.	Accuracy	1
5.	Title Block	1
TOTAL		5

Marks out of 20 will be distributed as given below:

1.	3 Project sheets × 5 Marks	15 Marks
2.	Viva-Voce (Visiting Examiner)	5 Marks
TOTAL		20 Marks

Instructions for Project Work:

- Candidates must use A2 size (**Half Imperial**) drawing sheets to complete all projects. A sample project sheet layout with specifications, is given below:

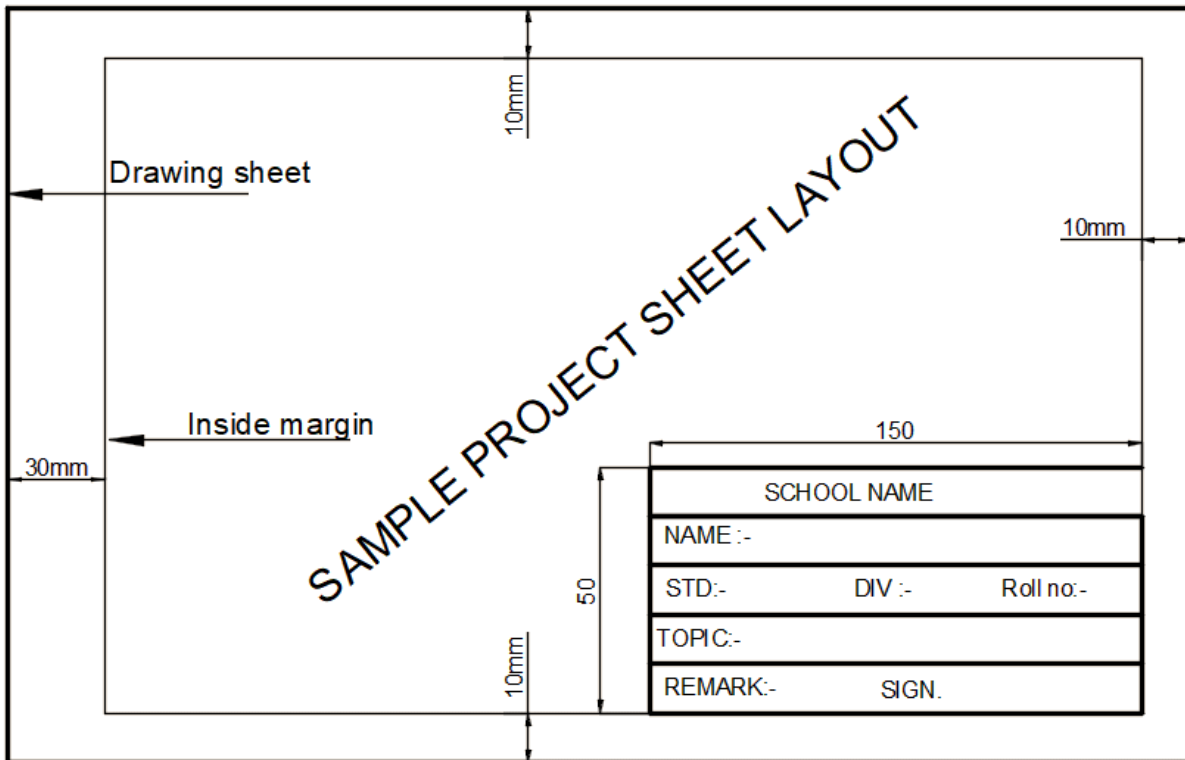

- Candidates must use the given layout and specifications to complete each project sheet.
- Accuracy, neat and clean work is expected from candidates while completing the project sheets.
- Candidates need **not** draw / paste the questions.
- For assembly drawing, candidates need to draw:
 - (i) Full sectional F.V.
 - (ii) T.V. by using 1st **OR** 3rd angle method of projection (omitting all the hidden lines)

PROJECT SHEETS

Candidates are required to have completed **three** project sheets, selecting at least **one** from **Section A** (Orthographic Projections) and **one** from **Section B** (Assembly Drawings).

SECTION A - ORTHOGRAPHIC PROJECTIONS

Project Sheet 1

Draw by using 1st OR 3rd angle method of projection i) F.V, ii) T.V. & iii) L.H.S.V

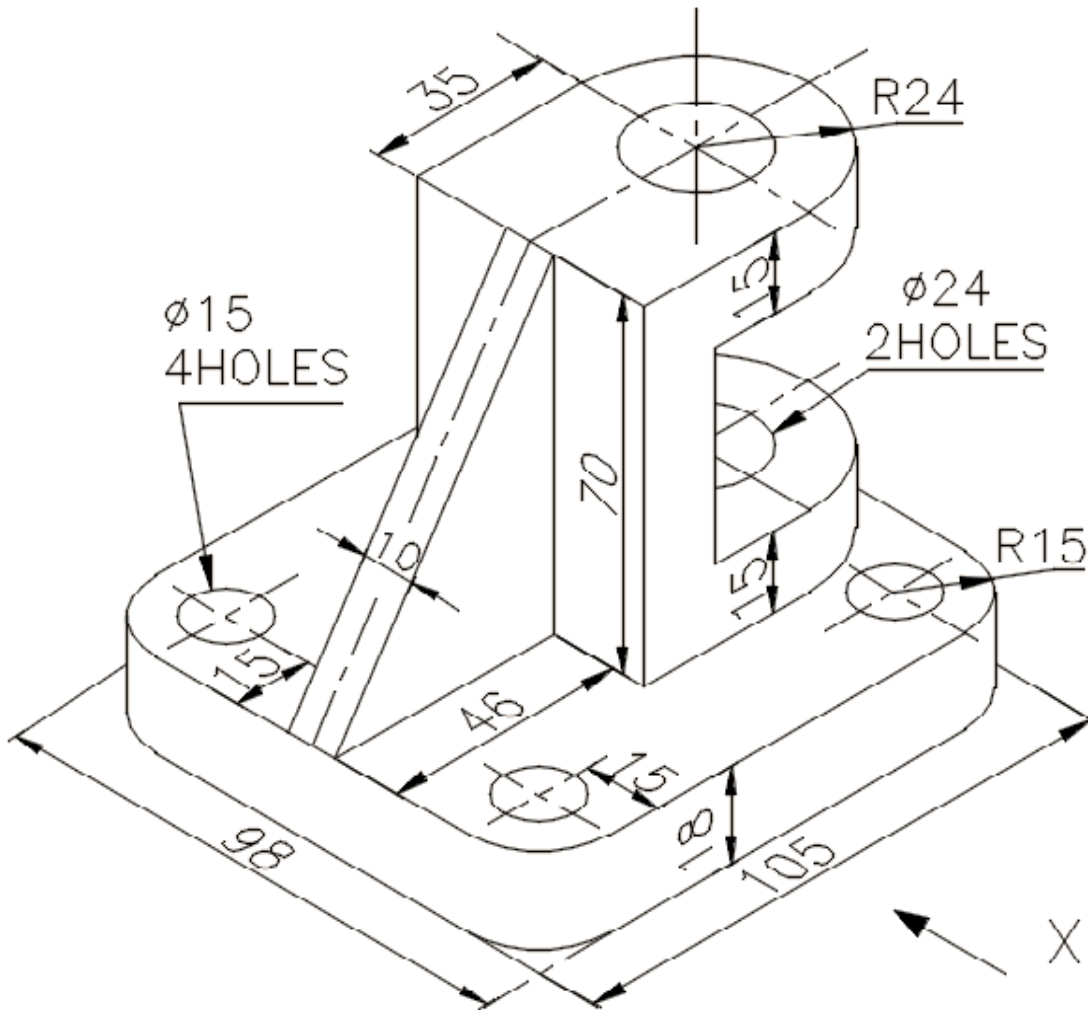

Project Sheet 2

Draw by using 1st OR 3rd angle method of projection i) F.V, ii) T.V. & iii) R.H.S.V

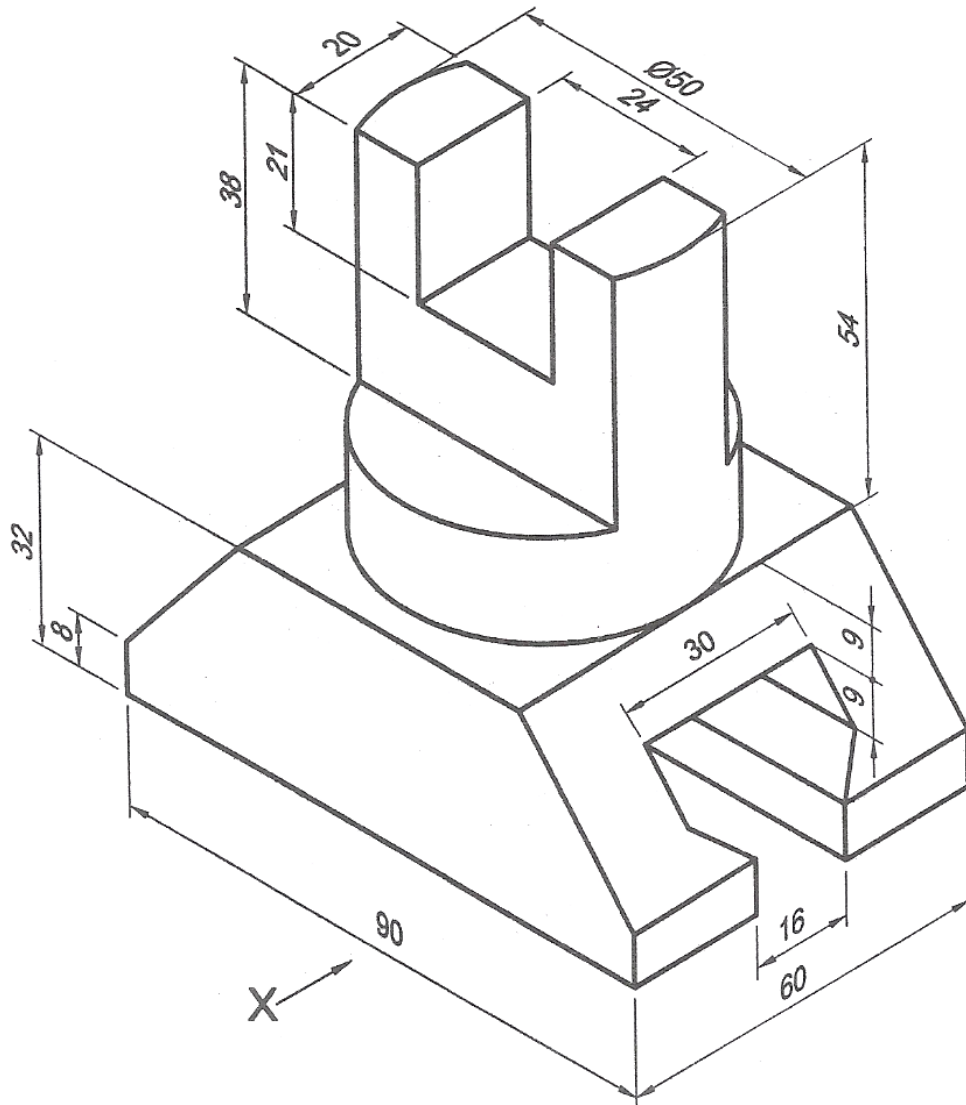

Project Sheet 3

Draw by using 1st OR 3rd angle method of projection i) F.V, ii) T.V. & iii) L.H.S.V

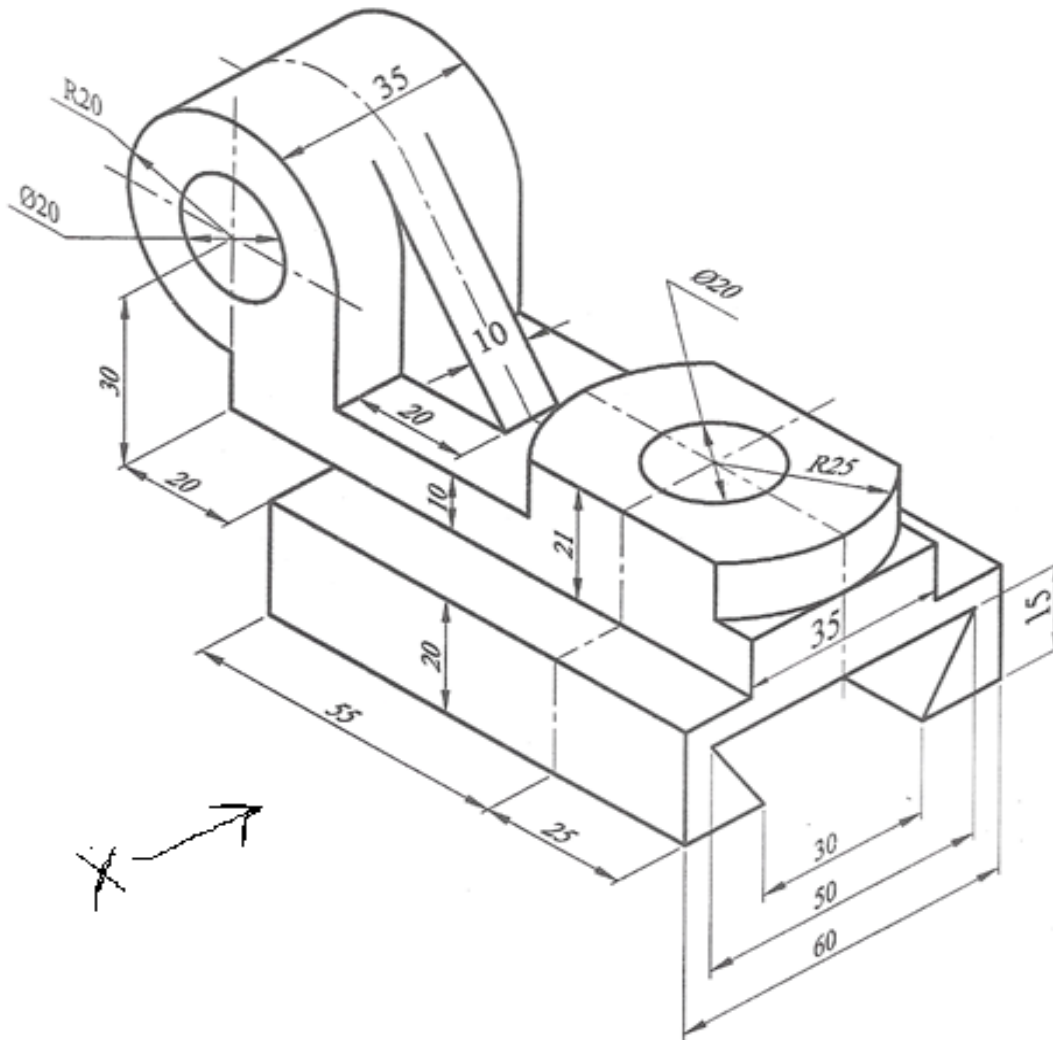

Project Sheet 4

Draw by using 1st OR 3rd angle method of projection i) F.V, ii) T.V. & iii) L.H.S.V

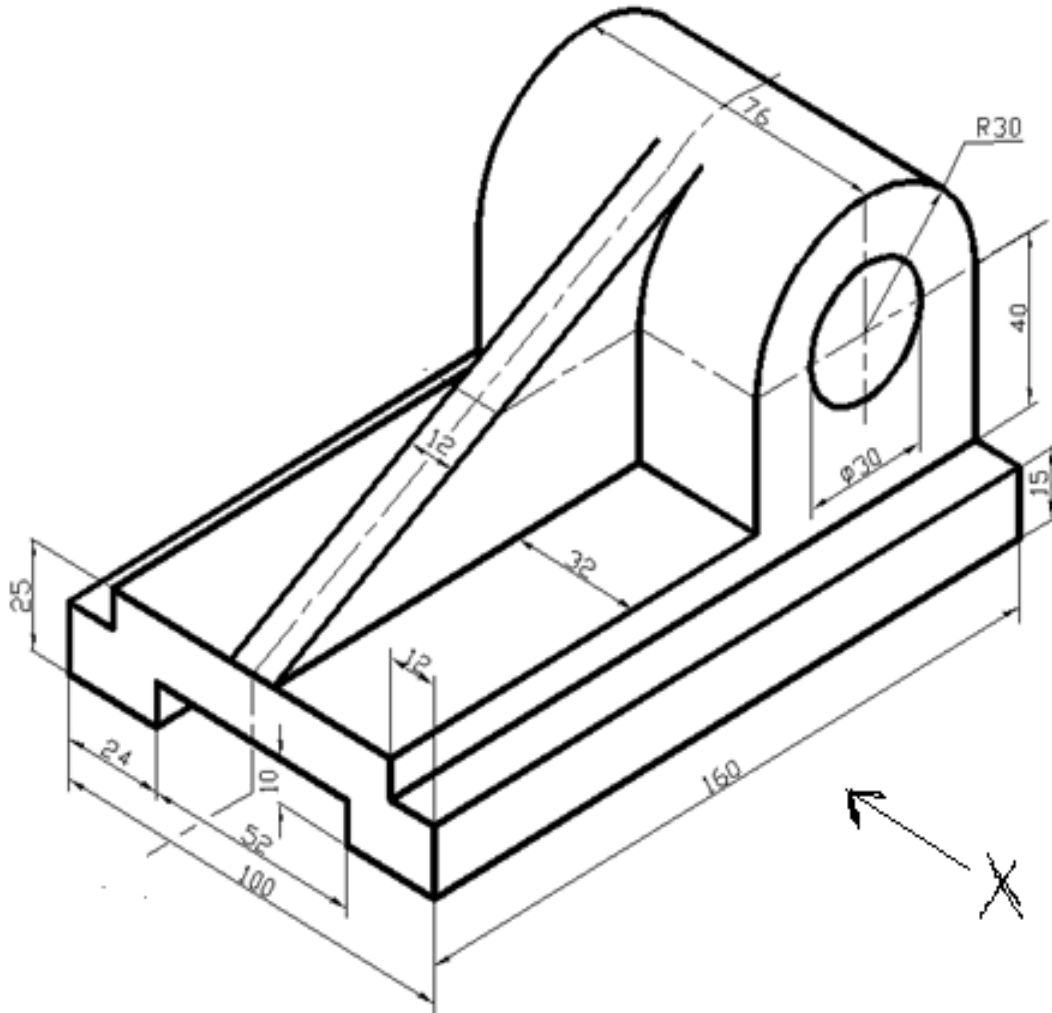

SECTION B - ASSEMBLY DRAWINGS

Project Sheet 1

Draw full sectional F.V & T.V of the following details of machine Parts. (omitting all hidden details)

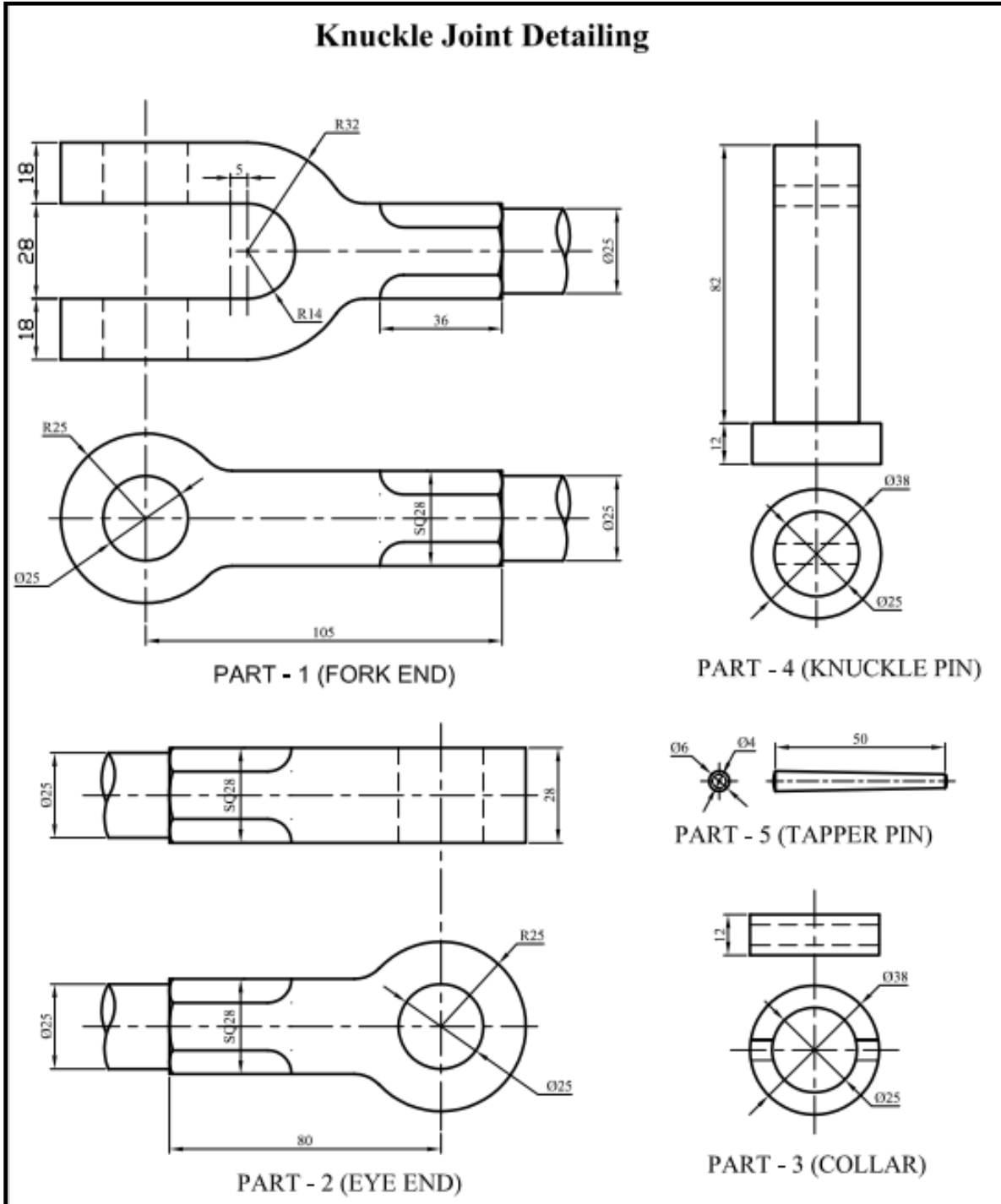

Project Sheet 2

Draw full sectional F.V. & T.V. of the following details of machine Parts. (omitting all hidden details)

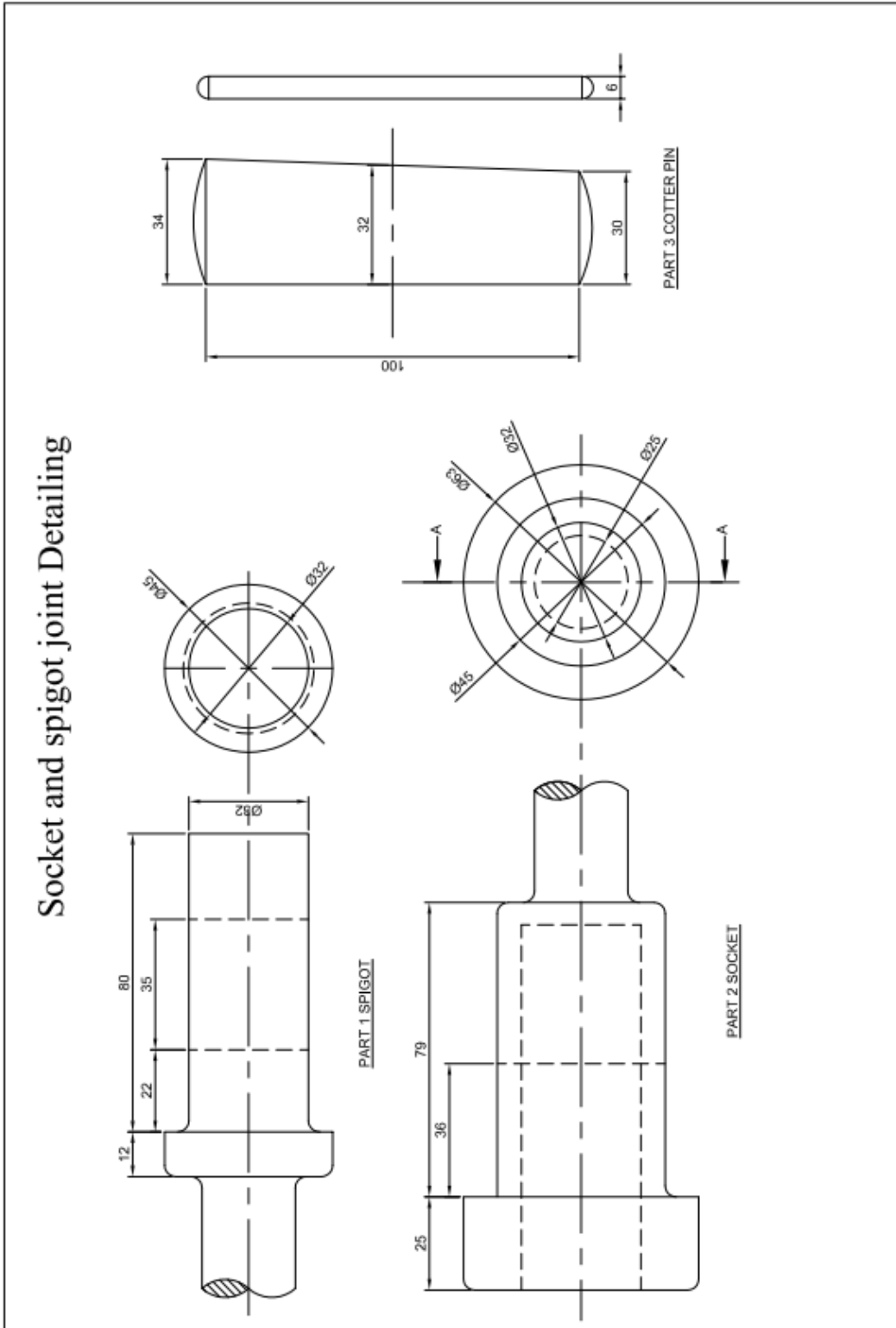

Project Sheet 3

Draw full sectional F.V & T.V of the following details of machine Parts. (omitting all hidden details)

PIPE VICE DETAILING

Part No.	Name	Matl	Qty
1	Vice base	Cl	1
2	Movable jaw	Cl	1
3	Set screw	MS	2
4	Screw rod	MS	1
5	Handle bar	MS	1
6	handle bar cup	MS	2

Project Sheet 4

Draw full sectional F.V & T.V of the following details of machine Parts. (omitting all hidden details)

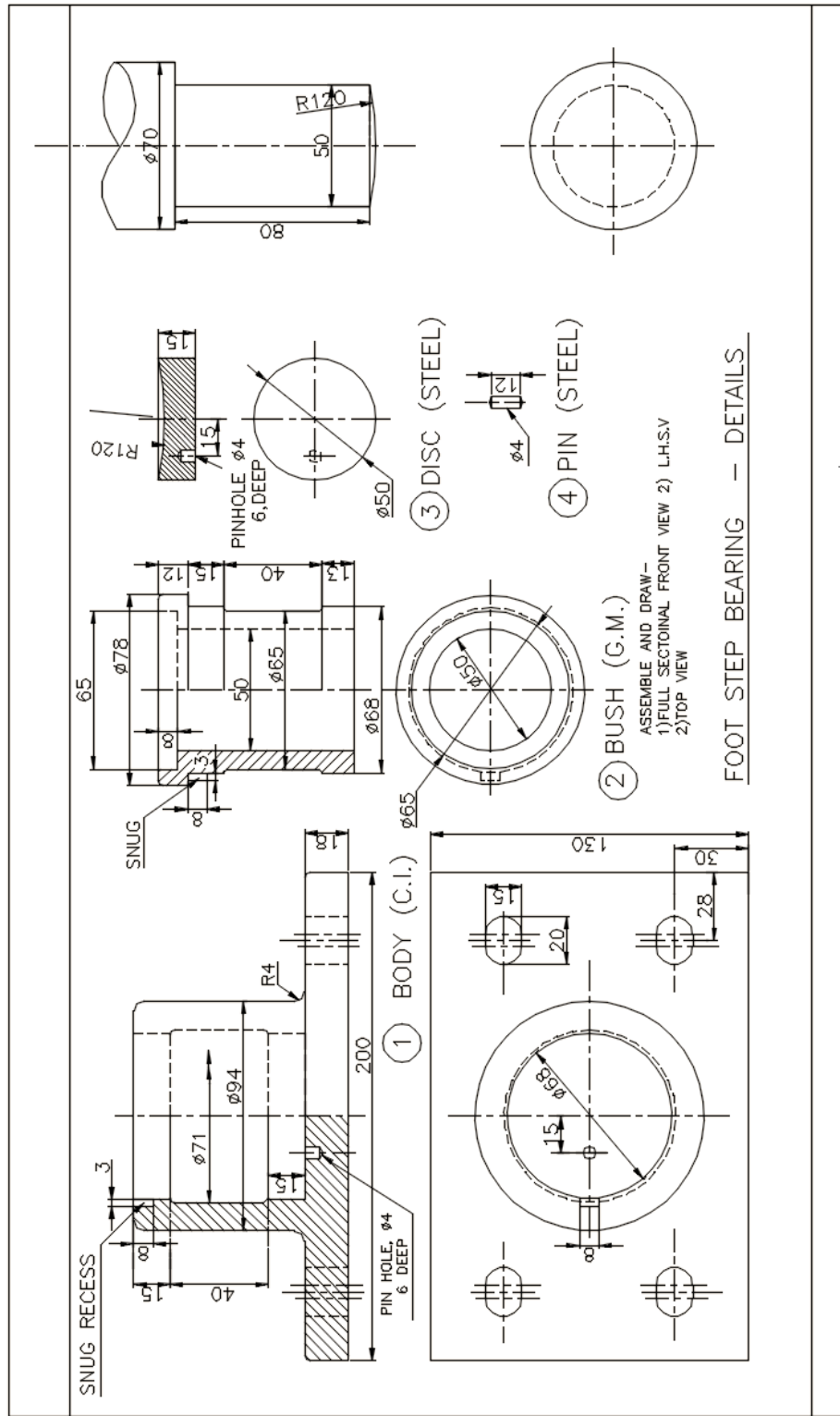

SAMPLE TABLE FOR PROJECT WORK

S. No.	Unique Identification Number (Unique ID) of the candidate	<u>PROJECT SHEETS</u>				TOTAL MARKS
		(Total 3 sheets of 5 marks each)				
		A	B	C	D	
		Teacher	Visiting Examiner	Average Marks (A + B ÷ 2)	Viva-Voce by Visiting Examiner on all three project sheets	
		15 Marks	15 Marks	15 Marks	5 Marks	20 Marks
1						
2						
3						
4						
5						
6						
7						
8						
9						
10						

*For breakup of the 5 Marks (for each project sheet) to be awarded separately by the Teacher and the Visiting Examiner, please refer to the table giving the criteria for mark allocation for *each* project.

NOTE: VIVA-VOCE of 5 Marks on the Project Sheets is to be conducted only by the Visiting Examiner and should be based on the Project Sheets only.