

CLASS 9 MATHS NOTES

HERON'S FORMULA

CHAPTER-12

HERON'S FORMULA

KEY POINTS

- Rectangle : If length and breadth of a rectangle is 'l' and 'b' respectively then

- (i) Perimeter of rectangle = $2(l + b)$ units
- (ii) Area of rectangle = $l \times b$ sq. units
- (iii) Diagonal of rectangle = $\sqrt{l^2 + b^2}$ units

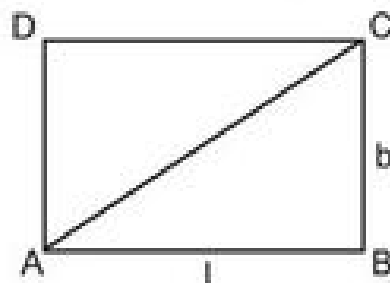

- Square : If 'a' is the length of side of a square

- (i) Perimeter of square = $4a$ units
- (ii) Area of square = $(\text{side})^2 = (a)^2$ sq. units
- (iii) Area of square = $\frac{1}{2} \times (\text{diagonal})^2$

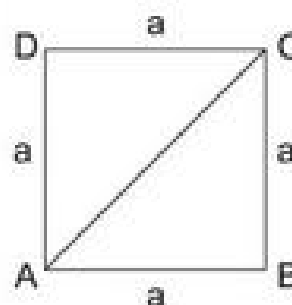

- Triangle :

- (A) Equilateral Triangle : In this triangle all three sides are equal. If the length of each side is 'a' then

- (i) Perimeter = $3a$ units
- (ii) Altitude = $\frac{\sqrt{3}}{2} a$ units
- (iii) Area = $\frac{\sqrt{3}}{4} a^2$ or $\frac{\sqrt{3}}{4} (\text{side})^2$ sq. units

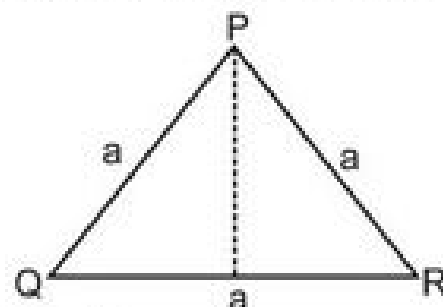

- (B) Right Angled Triangle : If one of the angles of a triangle is 90° .

- (i) Hypotenuse $k = \sqrt{b^2 + h^2}$ units
- (ii) Perimeter = $b + h + k$ units
- (iii) Area = $\frac{1}{2} \times b \times h$ sq. units

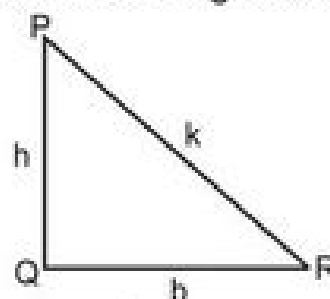

Area of triangle (General Formula)

$$= \frac{1}{2} \times \text{base} \times \text{Corresponding Altitude}$$

$$= \frac{1}{2} \times b \times h \text{ sq. units}$$

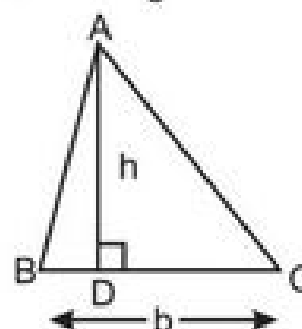

HERON'S FORMULA

- If the sides of triangle are a, b and c

(i) Perimeter = $a + b + c$

(ii) Semi Perimeter (S) = $\frac{a+b+c}{2}$

(iii) Area of Triangle (ΔABC) = $\sqrt{s(s-a)(s-b)(s-c)}$

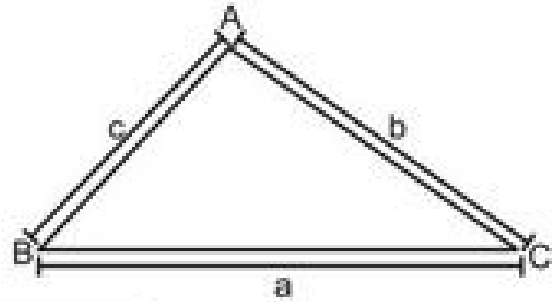

Note : Heron's formula is applicable to all types of triangles.

- Area of Parallelogram : If a is the length and b is breadth of a parallelogram and h be the height or perpendicular distance between two parallel sides then.

Area of parallelogram (ABCD)
 = Base x Corresponding Height
 = AB x DE
 = $a \times h$ sq. units

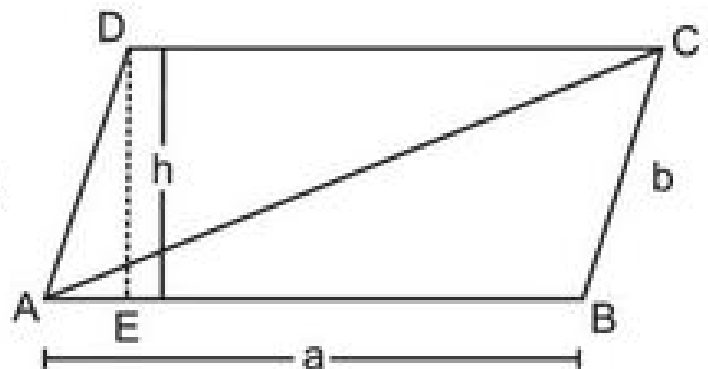

Area of $\Delta ABC = \frac{1}{2} \times$ Area of Parallelogram

- Area of Trapezium : Trapezium with parallel sides a and b and the perpendicular distance between two parallel sides as h.

Area of trapezium
 = $\frac{1}{2} \times (a + b) \times h$
 = $\frac{1}{2} \times$ (sum of parallel sides) x height

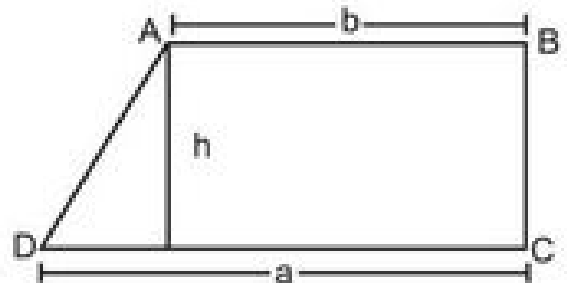

Important Questions with Solutions

Part – A

1. Find the area of a triangle whose base and altitudes are 8cm and 5cm.
2. Find the area of an equilateral triangle whose sides are 4cm each.
3. If sum of two sides of a triangle is 17cm and its perimeter is 30cm, then what is the length of third side.
4. If perimeter of a triangle is 24cm and sides are in the ratio 2 : 1 : 3, then find the longest side?

5. If each sides of a triangle is doubled then how many times the perimeter of triangle increased?
6. If area of a triangle is 50cm^2 and one of its sides is 10cm then find the length of corresponding altitude.
7. The area of an equilateral triangle is $16\sqrt{3}\text{ cm}^2$ then what will be the length of each side of that triangle?
8. Find the ratio between the area ΔABC and area ΔACD of the given rectangle.

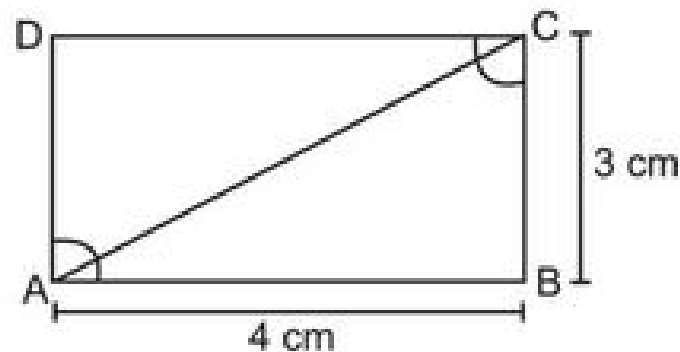

9. A square has each side of 5cm . Find the length of one of its diagonals.
10. If the length and corresponding height of a parallelogram are 10 cm and 8cm then find the area of a triangle made by its diagonal.
11. If one side of a triangle is 9.5 m and its corresponding altitude is 12m then what will be the area of triangle.

Part – B

12. If $(s - a) = 5\text{ cm}$
 $(s - b) = 10\text{ cm}$
 $(s - c) = 1\text{ cm}$. Find a, b & c
 where a, b & c are sides of the triangle.
13. The ratio between the sides of a triangle are $3 : 5 : 7$ and its perimeter is 300cm find the sides of triangle.
14. Find the cost of fencing the ground in the form of a triangle with sides 16 m , 12 m and 18 m . The rate of fencing is Rs. 25 per meter.
15. Find the area of isosceles triangle whose non equal side of 12 cm having the corresponding altitude is 7.5 cm .
16. The parallel side of a trapezium is 77m and 60m and its non parallel sides are 26m and 25m . Find the area of trapezium.

17. Find the area of rhombus in which $AB = 5$ cm and $AC = 8$ cm.

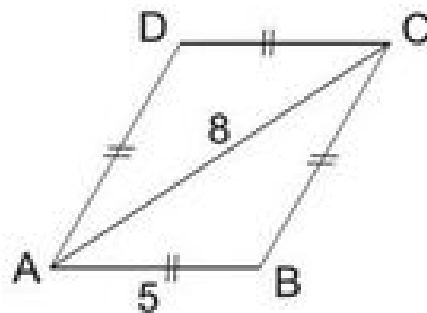

18. If in a triangle $AB = 15$ cm, $BC = 14$ cm and $AC = 13$ cm. Find the area of $\triangle ABC$ and hence its altitude corresponding to side BC .
19. Show that the Area of an equilateral triangle is $\frac{\sqrt{3}}{4} x^2$, where side is x .
20. Perimeter of an isosceles triangle is 32 cm. The ratio of equal side to its base is 3 : 2. Find area of this triangle.

Part – C

21. The area of a quadrilateral is 360m^2 and the perpendiculars drawn to one of the diagonal from the opposite vertices are 10m and 8m. Find the length of the diagonal.
22. If in a triangle with sides a, b & c , $(s - a) = 5$ cm,
 $(s - b) = 10$ cm and $(s - c) = 1$ cm, Find area of the triangle.
23. The cost of levelling a park is 2,700 for each 2 km^2 . If the park is in right angled triangular form with one side being 45 km. Find the hypotenuse.
24. Find the area of shaded region in the figure.

How many triangular flower beds of 6m^2 can be made from this area.

Use $\sqrt{105} = 10.25$

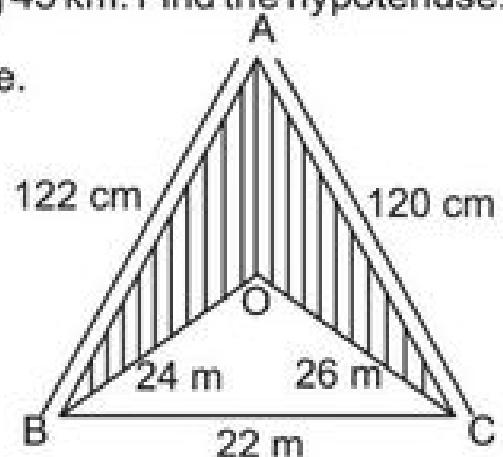

25. Find the area of rhombus whose perimeter is 100 m and one of whose diagonal is 30 m.
26. The sides of a triangle shaped sheet are 5 cm, 12 cm and 13 cm. Find the cost of painting on the sheet at the rate of ₹ 30 per cm^2 .
27. One side of a right angled triangle is 20 cm and the difference in lengths of its hypotenuse & other side is 8 cm. Find the other sides and area of the triangle.

28. Find the ratio between the area of triangle $\triangle ABC$ and $\triangle DEF$.

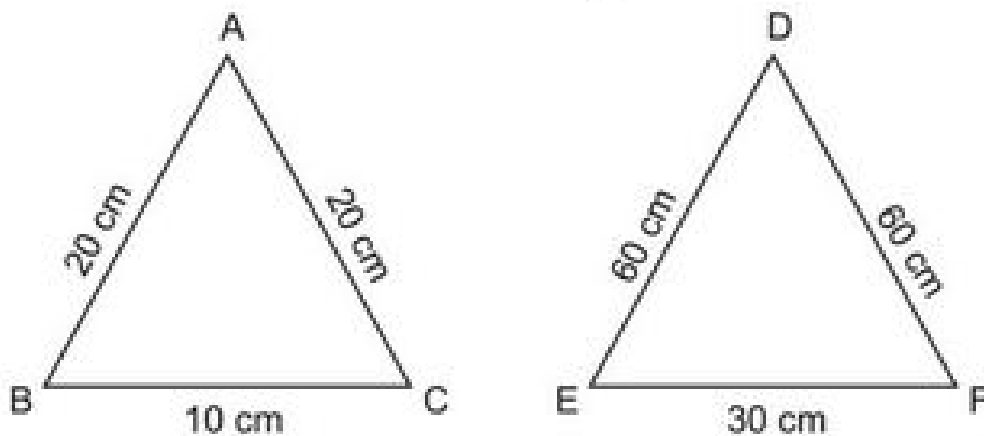

29. If perimeter of a triangle is x cm and its sides are p , q and r cm. What will be the area of triangle? Use the Heron's formula.

Part – D

30. A Triangular park ABC has sides 120 m, 80m and 50 m. A gardner has to put a fence all around it and also plant some trees inside the garden to get clean air.
- Find the cost of fencing it at the rate of Rs. 50 per meter. Leaving space 5 cm wide for the gate on one side.
 - Find its area where gardner may plant the tree.
31. A piece of land is in the shape as given in the figure, has been cut along diagonal AC. The two pieces of land has been distributed between Ram and Sohan. Who will get larger piece of land in terms of area? [Use $\sqrt{10} = 3.15$]

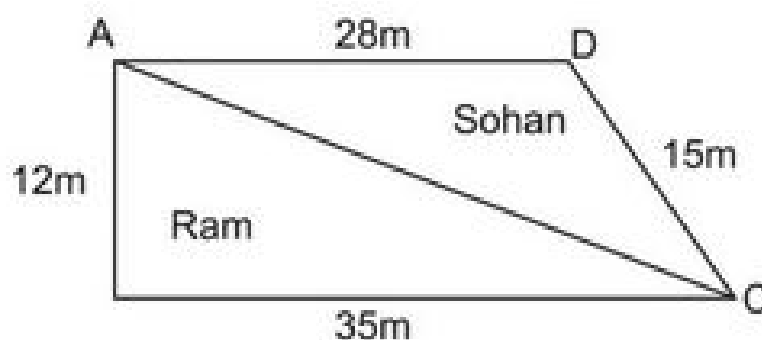

32. A triangular hoarding of dimensions 11m, 6m and 15m is used for commercial activities. The hoarding yield an earning of d 5000 per m^2 per month.

Calculate the total earning by the hoarding in a month. [Use $\sqrt{2} = 1.41$]

33. If each side of a triangle is doubled, find the ratio of the areas of two triangles, the given triangle & the triangle obtained on doubling the sides. Also find the percentage increase in the area of new triangle.

CHAPTER-12
HERON'S FORMULA

ANSWERS

- | | | |
|------------------------------|-------------------------------|---------------------------|
| 1. 20 cm^2 | 2. $4\sqrt{3} \text{ cm}^2$ | 3. 13 cm |
| 4. 12 cm | 5. one time | 6. 10 cm |
| 7. 8 cm | 8. 1 : 1 | 9. $5\sqrt{2} \text{ cm}$ |
| 10. 40 cm^2 | 11. 57 m^2 | 12. 11 cm, 6 cm 15 cm |
| 13. 60cm, 100cm, 140cm | | 14. ₹ 1150 |
| 15. 45 cm^2 | 16. 1644 m^2 | 17. 24 cm^2 |
| 18. 84 cm^2 , 12cm | 20. $32\sqrt{2} \text{ cm}^2$ | |
| 21. 40 m | 22. $20\sqrt{2} \text{ m}^2$ | 23. 75 km |
| 24. 1074 m^2 , 179 | 25. 600 m^2 | 26. ₹ 900 |
| 27. 29 cm, 21 cm | 28. 1 : 9 | |

29. $\sqrt{\frac{x}{2}\left(\frac{x}{2} - p\right)\left(\frac{x}{2} - q\right)\left(\frac{x}{2} - r\right)}$

- | | |
|---------------------------|---------------------------------|
| 30. (i) ₹ 12250 | (ii) $375\sqrt{15} \text{ m}^2$ |
| 31. Ram 210 m^2 | 32. R 141000 |
| 33. (i) 1:4 | |
| (ii) 300% | |

PRACTICE TEST
HERON'S FORMULA

Time : 50 Min.

M.M. 20

1. Find the length to sides of an equilateral triangles having area $a\sqrt{3} \text{ cm}^2$. 1
2. If $(s - a) = 5 \text{ cm}$, $(s - b) = 10 \text{ cm}$, $(s - c) = 1 \text{ cm}$. Find S . 1
3. Find the area of isosceles triangle whose equal sides are of length 15 cm each & the third side is 12 cm. 2
4. If each side of triangle is doubled, then find the ratio of area of new triangle thus formed & the given triangle. 2
5. The sides of a triangle are in the ratio 25 : 17 : 12 and its perimeter is 540 cm. Find the area of the triangle. 3
6. The area of trapezium is 475 cm^2 & height is 19 cm. Find length of its parallel sides if one side is 4 cm greater than the other. 3
7. The length of sides of a triangle are 7 cm, 12 cm & 13 cm. Find the length of perpendicular from opposite vertex to the side whose length is 12 cm. 4
8. The cost of fencing a field @ ₹ 5 per metre is ₹ 1920. If semi perimeter is 48 cm find its area & all sides. 4