

## Question Paper Preview

**Notations :**

1. Options shown in green color and with ✓ icon are correct.
2. Options shown in red color and with ✘ icon are incorrect.

<b>Question Paper Name:</b>	Electronics and Communication Engineering 30th May 2018 Shift1
<b>Subject Name:</b>	Electronics and Communication Engineering
<b>Creation Date:</b>	2018-05-30 12:38:06
<b>Duration:</b>	120
<b>Total Marks:</b>	120
<b>Display Marks:</b>	No
<b>Calculator:</b>	None
<b>Magnifying Glass Required?:</b>	No
<b>Ruler Required?:</b>	No
<b>Eraser Required?:</b>	No
<b>Scratch Pad Required?:</b>	No
<b>Rough Sketch/Notepad Required?:</b>	No
<b>Protractor Required?:</b>	No

<b>Display Number Panel:</b>	Yes
<b>Group All Questions:</b>	No

Question Number : 1 Question Id : 5113467681 Question Type : MCQ Option Shuffling : Yes Display Question Number : Yes  
Single Line Question Option : No Option Orientation : Vertical

F is a field of complex numbers. The vectors  $(x_1, x_2)$  and  $(y_1, y_2)$  in the vector space  $V_2(F)$  are linearly dependent if and only if

**Options :**

1. ✘  $x_1y_1 - x_2y_2 = 0$
2. ✘  $x_1x_2 - y_1y_2 = 0$
3. ✓  $x_1y_2 - x_2y_1 = 0$
4. ✘  $x_1y_2 + x_2y_1 = 0$

Question Number : 2 Question Id : 5113467682 Question Type : MCQ Option Shuffling : Yes Display Question Number : Yes  
Single Line Question Option : No Option Orientation : Vertical

If the rank of the matrix  $A = \begin{bmatrix} 1 & -2 & 3 \\ 2 & 1 & -1 \\ 6 & -2 & \lambda \end{bmatrix}$  is 2 then the value of  $\lambda =$

Options :

1. ✓  $\lambda = 4$

2. ✗  $\lambda = 3$

3. ✗  $\lambda = 2$

4. ✗  $\lambda = 0$

Question Number : 3 Question Id : 5113467683 Question Type : MCQ Option Shuffling : Yes Display Question Number : Yes  
Single Line Question Option : No Option Orientation : Vertical

If  $A = \begin{bmatrix} 1 & 4 \\ 1 & 2 \end{bmatrix}$ , the eigen values of A are

Options :

1. ✗ 1 and 4

2. ✗ 1 and 5

3. ✗ 2 and 4

4. ✓ 1 and 6

Question Number : 4 Question Id : 5113467684 Question Type : MCQ Option Shuffling : Yes Display Question Number : Yes  
Single Line Question Option : No Option Orientation : Vertical

If  $u = \log \frac{x^2}{y}$ , then  $x \frac{\partial u}{\partial x} + y \frac{\partial u}{\partial y} =$

Options :

1. ✓ 1

2. ✗  $\frac{1}{u}$

3. ✘  $2u$

4. ✘ 0 (zero)

Question Number : 5 Question Id : 5113467685 Question Type : MCQ Option Shuffling : Yes Display Question Number : Yes  
Single Line Question Option : No Option Orientation : Vertical

The value of  $\int_0^a \frac{dx}{\sqrt{a-x}} =$

Options :

1. ✘  $\sqrt{a}$

2. ✘  $\frac{1}{\sqrt{a}}$

3. ✔  $2\sqrt{a}$

4. ✘  $\frac{2}{\sqrt{a}}$

Question Number : 6 Question Id : 5113467686 Question Type : MCQ Option Shuffling : Yes Display Question Number : Yes  
Single Line Question Option : No Option Orientation : Vertical

The integrating factor when the differential equation  $y^2 dx + (xy-1)dy = 0$  is changed to linear form is

Options :

1. ✘ X

2. ✔ y

3. ✘  $\frac{1}{x}$

4. ✘  $\frac{1}{y}$

Question Number : 7 Question Id : 5113467687 Question Type : MCQ Option Shuffling : Yes Display Question Number : Yes  
Single Line Question Option : No Option Orientation : Vertical

The general solution of the differential equation  $\frac{dy}{dx} = \log(x \frac{dy}{dx} - y)$  is

Options :

1. ✓  $y = cx - e^c$
2. ✗  $y = cx + e^c$
3. ✗  $y = cx + \log c$
4. ✗  $y = cx - \log c$

Question Number : 8 Question Id : 5113467688 Question Type : MCQ Option Shuffling : Yes Display Question Number : Yes  
Single Line Question Option : No Option Orientation : Vertical

The Particular integral of  $(D^2+1)y = \cos x$  where  $D = \frac{d}{dx}$  is

Options :

1. ✗  $x \sin x$
2. ✗  $x \cos x$
3. ✓  $\frac{x \sin x}{2}$
4. ✗  $\frac{x \cos x}{2}$

Question Number : 9 Question Id : 5113467689 Question Type : MCQ Option Shuffling : Yes Display Question Number : Yes  
Single Line Question Option : No Option Orientation : Vertical

The solution of the partial differential equation  $pe^y = qe^x$  is  $z =$

Options :

1. ✓  $ae^x + ae^y + c$
2. ✗  $ae^{-x} + ae^{-y} + c$

3. ✘  $ae^x + be^y + c$

4. ✘  $ae^x - be^y + c$

Question Number : 10 Question Id : 5113467690 Question Type : MCQ Option Shuffling : Yes Display Question Number : Yes  
Single Line Question Option : No Option Orientation : Vertical

The Residue of  $f(z) = \frac{ze^{iz}}{z^2+a^2}$  at  $z = -ai$  is

Options :

1. ✘  $\frac{1}{2}e^{ia}$

2. ✘  $\frac{1}{2}e^{-ia}$

3. ✘  $\frac{1}{2}e^{-a}$

4. ✔  $\frac{1}{2}e^a$

Display Number Panel:

Yes

Group All Questions:

No

Question Number : 11 Question Id : 5113467691 Question Type : MCQ Option Shuffling : Yes Display Question Number : Yes  
Single Line Question Option : No Option Orientation : Vertical

A certain number of resistors connected in parallel has an effective resistance of  $X \Omega$ . The effective resistance changes to  $Y \Omega$  when one of the resistors is removed. The resistance of the resistor that is removed is:

Options :

1. ✘  $\sqrt{XY}$

2. ✘  $\frac{(Y-X)}{XY}$

3. ✘  $(Y - X)$

4. ✔  $\frac{XY}{(Y-X)}$

Question Number : 12 Question Id : 5113467692 Question Type : MCQ Option Shuffling : Yes Display Question Number : Yes  
Single Line Question Option : No Option Orientation : Vertical

The maximum current that an  $80 \text{ k}\Omega$ ,  $2 \text{ W}$  resistor can safely conduct is:

Options :

1. ✘  $25 \mu\text{A}$

2. ✔  $5 \text{ mA}$

3. ✘  $40 \text{ mA}$

4. ✘  $160 \text{ mA}$

Question Number : 13 Question Id : 5113467693 Question Type : MCQ Option Shuffling : Yes Display Question Number : Yes  
Single Line Question Option : No Option Orientation : Vertical

The voltage  $V_x$  across the  $5\Omega$  resistor in the circuit shown below is:

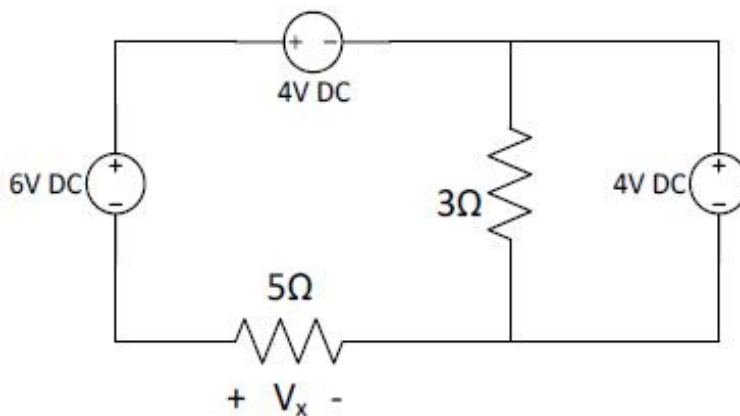

Options :

1. ✔  $2 \text{ V}$

2. ✘  $-2 \text{ V}$

3. ✘  $14 \text{ V}$

4. ✘ 10 V

Question Number : 14 Question Id : 5113467694 Question Type : MCQ Option Shuffling : Yes Display Question Number : Yes  
Single Line Question Option : No Option Orientation : Vertical

In the circuit shown below, the switch was initially open for a very long time and the capacitor is without charge. If the switch is now closed at time  $t = 0$  s, then the value of time constant for the circuit is:

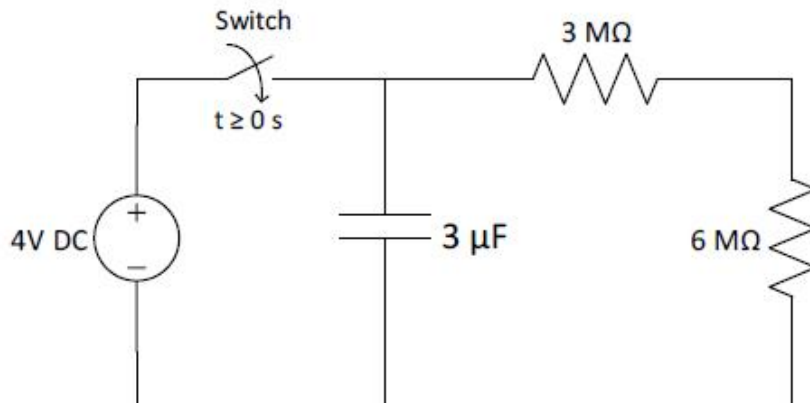

Options :

1. ✔ zero
2. ✘ 4 seconds
3. ✘ 6 seconds
4. ✘ 27 seconds

Question Number : 15 Question Id : 5113467695 Question Type : MCQ Option Shuffling : Yes Display Question Number : Yes  
Single Line Question Option : No Option Orientation : Vertical

For the op-amp circuit shown below, the power absorbed by the  $4\text{ k}\Omega$  resistor is:

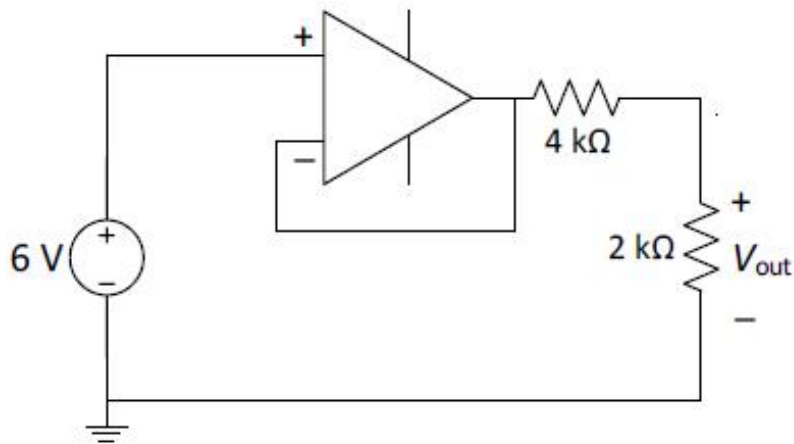

Options :

1. ✘ 2 mW
2. ✔ 4 mW
3. ✘ 6 mW
4. ✘ 9 mW

Question Number : 16 Question Id : 5113467696 Question Type : MCQ Option Shuffling : Yes Display Question Number : Yes Single Line Question Option : No Option Orientation : Vertical

The resistance between the nodes  $A$  and  $B$  for the resistive bridge circuit shown below is:

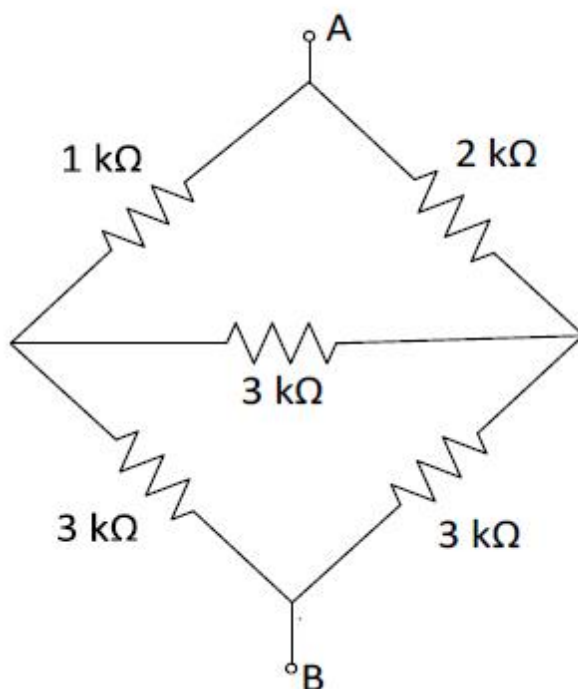

Options :

1. ✓ 2.2 k $\Omega$
2. ✗ 3 k $\Omega$
3. ✗ 3.25 k $\Omega$
4. ✗ 5.21 k $\Omega$

Question Number : 17 Question Id : 5113467697 Question Type : MCQ Option Shuffling : Yes Display Question Number : Yes  
Single Line Question Option : No Option Orientation : Vertical

For the circuit shown below,  $v_1$  and  $v_2$  are related as:

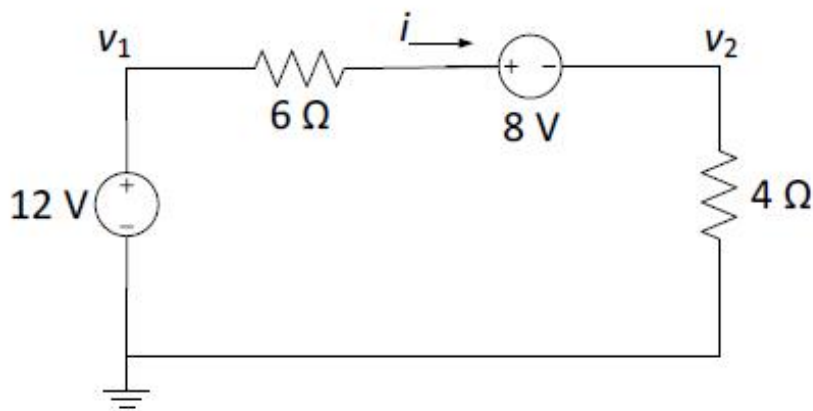

Options :

1. ✗  $v_1 = 6i - 8 + v_2$
2. ✗  $v_1 = -6i + 8 + v_2$
3. ✗  $v_1 = -6i - 8 + v_2$
4. ✓  $v_1 = 6i + 8 + v_2$

Question Number : 18 Question Id : 5113467698 Question Type : MCQ Option Shuffling : Yes Display Question Number : Yes  
Single Line Question Option : No Option Orientation : Vertical

A load is connected to a network. At the terminals to which the load is connected, the Thevenin voltage and Thevenin resistance are 40 V and 10  $\Omega$  respectively. The maximum power supplied to the load is:

Options :

1. ✗ 4 W

2. ✓ 40 W
3. ✗ 80 W
4. ✗ 160 W

Question Number : 19 Question Id : 5113467699 Question Type : MCQ Option Shuffling : Yes Display Question Number : Yes  
Single Line Question Option : No Option Orientation : Vertical

For the circuit shown below, the Thevenin impedance at terminals  $A-B$  is:

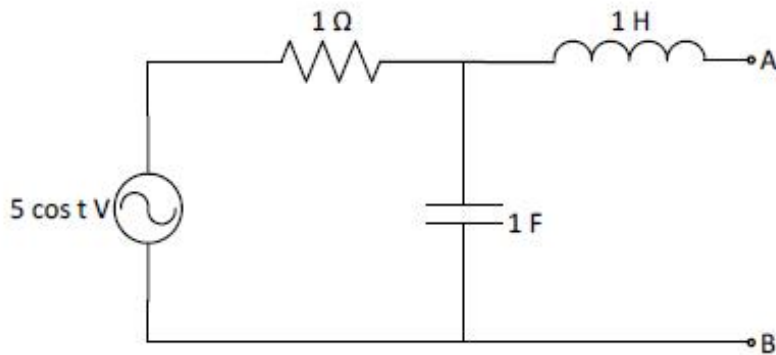

Options :

1. ✓  $(0.5 + j0.5) \Omega$
2. ✗  $1 \Omega$
3. ✗  $(1 + j2) \Omega$
4. ✗  $(1 - j2) \Omega$

Question Number : 20 Question Id : 5113467700 Question Type : MCQ Option Shuffling : Yes Display Question Number : Yes  
Single Line Question Option : No Option Orientation : Vertical

An LC-circuit has a  $Q$  of 100 and resonates at 1000 kHz. The lower and upper cut-off frequencies of this circuit are:

Options :

1. ✓ 995 kHz and 1005 kHz
2. ✗ 990 kHz and 1010 kHz

3. ✘ 950 kHz and 1050 kHz

4. ✘ 900 kHz and 1100 kHz

Question Number : 21 Question Id : 5113467701 Question Type : MCQ Option Shuffling : Yes Display Question Number : Yes  
Single Line Question Option : No Option Orientation : Vertical

A series  $RLC$  circuit, with  $R$  set to  $0 \Omega$ , will produce a/an:

Options :

1. ✔ undamped response

2. ✘ underdamped response

3. ✘ critically damped response

4. ✘ overdamped response

Question Number : 22 Question Id : 5113467702 Question Type : MCQ Option Shuffling : Yes Display Question Number : Yes  
Single Line Question Option : No Option Orientation : Vertical

In the circuit shown below, the current  $i(t)$  is:

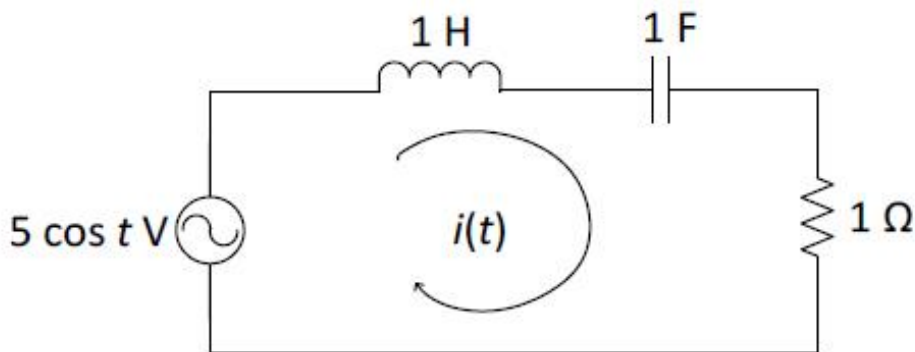

Options :

1. ✔  $5 \cos t$  A

2. ✘  $5 \sin t$  A

3. ✘  $10 \cos t$  A

4. ✘  $2.24 \cos(t - 45^\circ) \text{ A}$

Question Number : 23 Question Id : 5113467703 Question Type : MCQ Option Shuffling : Yes Display Question Number : Yes  
Single Line Question Option : No Option Orientation : Vertical

A periodic signal  $(3 + 6 \sin \omega_0 t)$  volts is applied across a  $1\text{-}\Omega$  resistor. The power dissipated in the resistor is:

Options :

1. ✘ 9 W

2. ✘ 22.5 W

3. ✔ 27 W

4. ✘ 45 W

Question Number : 24 Question Id : 5113467704 Question Type : MCQ Option Shuffling : Yes Display Question Number : Yes  
Single Line Question Option : No Option Orientation : Vertical

For the single-element two-port network shown below,  $z_{11}$  is:

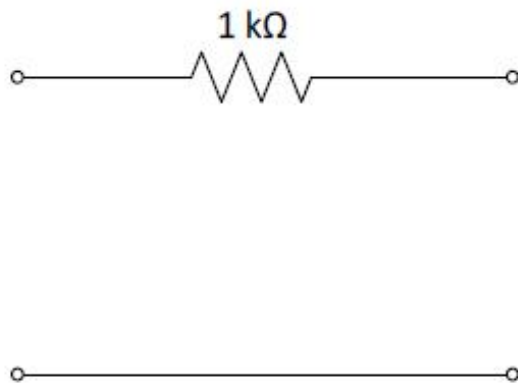

Options :

1. ✘ 0

2. ✘  $0.5 \text{ k}\Omega$

3. ✘  $1 \text{ k}\Omega$

4. ✔ Undefined

Question Number : 25 Question Id : 5113467705 Question Type : MCQ Option Shuffling : Yes Display Question Number : Yes  
Single Line Question Option : No Option Orientation : Vertical

The odd component of the signal  $x(t) = e^{jt}$  is:

Options :

1. ✘  $\cos t + j\sin t$
2. ✘  $\cos t$
3. ✘  $\sin t$
4. ✔  $j\sin t$

Question Number : 26 Question Id : 5113467706 Question Type : MCQ Option Shuffling : Yes Display Question Number : Yes  
Single Line Question Option : No Option Orientation : Vertical

Given that  $\delta(t)$  is the unit impulse function, the value of the integral  $\int_1^2 (2t^2 + 1) \delta(t) dt$  is:

Options :

1. ✘ 3
2. ✔ 0
3. ✘ 1
4. ✘  $\infty$

Question Number : 27 Question Id : 5113467707 Question Type : MCQ Option Shuffling : Yes Display Question Number : Yes  
Single Line Question Option : No Option Orientation : Vertical

Let  $E_x$  be the energy contained in a signal  $x(t)$ . Then the energy of the signal  $x(at)$  is:

Options :

1. ✔  $E_x/a$
2. ✘  $E_x/a^2$
3. ✘  $aE_x$
4. ✘  $a^2E_x$

Question Number : 28 Question Id : 5113467708 Question Type : MCQ Option Shuffling : Yes Display Question Number : Yes  
Single Line Question Option : No Option Orientation : Vertical

The period of a function  $x(t) = 2\cos\left[\frac{\pi}{4}(t - 1)\right]$  is:

Options :

1. ✓ 8 seconds
2. ✗ 4 seconds
3. ✗ (1/8) second
4. ✗ (1/4) second

Question Number : 29 Question Id : 5113467709 Question Type : MCQ Option Shuffling : Yes Display Question Number : Yes  
Single Line Question Option : No Option Orientation : Vertical

The convolution of a rectangular pulse of width  $W$  with an identical rectangular pulse yields a:

Options :

1. ✗ rectangular pulse of width  $2W$
2. ✓ triangular pulse of width  $2W$
3. ✗ a sinc function
4. ✗ trapezoidal pulse of width  $3W$

Question Number : 30 Question Id : 5113467710 Question Type : MCQ Option Shuffling : Yes Display Question Number : Yes  
Single Line Question Option : No Option Orientation : Vertical

The Fourier transform of a rectangular pulse is:

Options :

1. ✗ an impulse
2. ✓ a sinc function
3. ✗ another rectangular pulse

4. ✘ a triangular pulse

Question Number : 31 Question Id : 5113467711 Question Type : MCQ Option Shuffling : Yes Display Question Number : Yes  
Single Line Question Option : No Option Orientation : Vertical

Consider a periodic impulse train in the time domain. The Fourier transform of this impulse train is:

Options :

1. ✔ a periodic impulse train in the frequency domain
2. ✘ a Gaussian function
3. ✘ a constant
4. ✘ a sine function

Question Number : 32 Question Id : 5113467712 Question Type : MCQ Option Shuffling : Yes Display Question Number : Yes  
Single Line Question Option : No Option Orientation : Vertical

The Fourier transform of the signum function  $sgn(t)$  is:

Options :

1. ✘  $\pi\delta(\omega)$
2. ✘  $\pi\delta(\omega) + \frac{1}{j\omega}$
3. ✔  $\frac{2}{j\omega}$
4. ✘  $\frac{1}{1+j\omega}$

Question Number : 33 Question Id : 5113467713 Question Type : MCQ Option Shuffling : Yes Display Question Number : Yes  
Single Line Question Option : No Option Orientation : Vertical

Given that a signal  $x(t)$  has the Fourier transform  $X(\omega)$ , the Fourier transform of the signal  $x(1 - t)$  in terms of  $X(\omega)$  is:

Options :

1. ✘  $X(\omega)e^{j\omega}$

2. ✘  $X(\omega)e^{-j\omega}$

3. ✘  $X(-\omega)e^{j\omega}$

4. ✔  $X(-\omega)e^{-j\omega}$

Question Number : 34 Question Id : 5113467714 Question Type : MCQ Option Shuffling : Yes Display Question Number : Yes  
Single Line Question Option : No Option Orientation : Vertical

Consider an LTI system having the unit-impulse response  $h(t) = \delta(t) - e^{-t}u(t)$ , where  $\delta(t)$  and  $u(t)$  are the unit-impulse function and the unit-step function respectively. The Fourier transform of  $h(t)$  can be expressed as:

Options :

1. ✘  $H(\omega) = \delta(\omega) - \frac{1}{1-j\omega}$

2. ✘  $H(\omega) = \frac{1-j\omega}{1+j\omega}$

3. ✘  $H(\omega) = 1 - \frac{1}{1-j\omega}$

4. ✔  $H(\omega) = \frac{j\omega}{1+j\omega}$

Question Number : 35 Question Id : 5113467715 Question Type : MCQ Option Shuffling : Yes Display Question Number : Yes  
Single Line Question Option : No Option Orientation : Vertical

The discrete-time signal  $x(n) = 2(-1)^n$  has a fundamental period of:

Options :

1. ✘ 0

2. ✔ 2

3. ✘ 4

4. ✘ 8

Question Number : 36 Question Id : 5113467716 Question Type : MCQ Option Shuffling : Yes Display Question Number : Yes  
Single Line Question Option : No Option Orientation : Vertical

The discrete-time Fourier series coefficients of a real and odd periodic signal are:

Options :

1. ✘ real and odd
2. ✘ real and even
3. ✔ imaginary and odd
4. ✘ imaginary and even

Question Number : 37 Question Id : 5113467717 Question Type : MCQ Option Shuffling : Yes Display Question Number : Yes  
Single Line Question Option : No Option Orientation : Vertical

Consider a signal  $x(t)$  whose Laplace transform is  $X(s) = \frac{3}{s(s+1)}$ . The value of  $x(t)$  for  $t \rightarrow 0$  is:

Options :

1. ✔ 0
2. ✘  $\infty$
3. ✘ 3
4. ✘  $\frac{1}{3}$

Question Number : 38 Question Id : 5113467718 Question Type : MCQ Option Shuffling : Yes Display Question Number : Yes  
Single Line Question Option : No Option Orientation : Vertical

The  $z$ -transform of the signal  $\delta(n - m)$  is:

Options :

1. ✔  $Z^{-m}$
2. ✘  $Z^{-(n-m)}$
3. ✘  $\frac{1}{z-m}$

$$4. \times \frac{1}{z-(n-m)}$$

Question Number : 39 Question Id : 5113467719 Question Type : MCQ Option Shuffling : Yes Display Question Number : Yes  
Single Line Question Option : No Option Orientation : Vertical

A finite-length signal  $x(n]$  has the z-transform  $X(z) = 0.5 + 0.2z^{-1} + 0.7z^{-2} + 0.5z^{-3}$ . The region of convergence of the signal is:

Options :

1.  $\times$  on the unit circle
2.  $\times$  outside the unit circle
3.  $\times$  inside the unit circle
4.  $\checkmark$  the entire  $z$ -plane except  $z = 0$

Question Number : 40 Question Id : 5113467720 Question Type : MCQ Option Shuffling : Yes Display Question Number : Yes  
Single Line Question Option : No Option Orientation : Vertical

An LTI system (initially at rest) is given by the difference equation  $y(n) - y(n - 1) = x(n)$ . Its impulse response is:

Options :

1.  $\checkmark$   $y(n) = u(n)$
2.  $\times$   $y(n) = u(n - 1)$
3.  $\times$   $y(n) = nu(n)$
4.  $\times$   $y(n) = (-1)^{n+1}u(n)$

Question Number : 41 Question Id : 5113467721 Question Type : MCQ Option Shuffling : Yes Display Question Number : Yes  
Single Line Question Option : No Option Orientation : Vertical

A system given by the difference equation  $y(n) = nx(n) + 3$  is:

Options :

1. ✘ linear and time variant
2. ✘ linear and time-invariant
3. ✔ non-linear and time variant
4. ✘ non-linear and time-invariant

Question Number : 42 Question Id : 5113467722 Question Type : MCQ Option Shuffling : Yes Display Question Number : Yes  
Single Line Question Option : No Option Orientation : Vertical

The addition of a minute quantity of antimony to a silicon crystal makes the crystal a:

Options :

1. ✘ good insulator
2. ✘ good conductor
3. ✘ *p*-type semiconductor
4. ✔ *n*-type semiconductor

Question Number : 43 Question Id : 5113467723 Question Type : MCQ Option Shuffling : Yes Display Question Number : Yes  
Single Line Question Option : No Option Orientation : Vertical

What two quantities are connected by the Einstein relation?

Options :

1. ✔ The mobility and the diffusion coefficient
2. ✘ The diffusion coefficient and the minority carrier lifetime
3. ✘ The diffusion length and the minority carrier lifetime
4. ✘ The hole and electron mobilities

Question Number : 44 Question Id : 5113467724 Question Type : MCQ Option Shuffling : Yes Display Question Number : Yes  
Single Line Question Option : No Option Orientation : Vertical

When a piece of germanium and another of copper are cooled from room temperature to 100°K, the resistance of:

Options :

1. ✘ each of them decreases
2. ✘ each of them increases
3. ✘ germanium decreases and that of copper increases
4. ✔ germanium increases and that of copper decreases

Question Number : 45 Question Id : 5113467725 Question Type : MCQ Option Shuffling : Yes Display Question Number : Yes  
Single Line Question Option : No Option Orientation : Vertical

A sample of  $n$ -type silicon:

Options :

1. ✘ is negatively charged since it contains an excess of free electrons
2. ✘ predominantly contains trivalent impurities
3. ✘ contains only tetravalent impurities
4. ✔ contains an excess of free electrons and it is electrically neutral

Question Number : 46 Question Id : 5113467726 Question Type : MCQ Option Shuffling : Yes Display Question Number : Yes  
Single Line Question Option : No Option Orientation : Vertical

The electron concentration in Si at 300°K with a Boron doping of  $N_A = 10^{17} \text{ cm}^{-3}$  is:

Options :

1. ✘  $n = 10^{10} \text{ cm}^{-3}$
2. ✘  $n = 10^{17} \text{ cm}^{-3}$
3. ✔  $n = 10^3 \text{ cm}^{-3}$

4. ✘  $n = 10^6 \text{ cm}^{-3}$

Question Number : 47 Question Id : 5113467727 Question Type : MCQ Option Shuffling : Yes Display Question Number : Yes  
Single Line Question Option : No Option Orientation : Vertical

The thermal voltage  $V_t$  at room temperature ( $20^\circ\text{C}$ ) is approximately:

Options :

1. ✔ 25 mV

2. ✘ 25 V

3. ✘ 50 mV

4. ✘ 100  $\mu\text{V}$

Question Number : 48 Question Id : 5113467728 Question Type : MCQ Option Shuffling : Yes Display Question Number : Yes  
Single Line Question Option : No Option Orientation : Vertical

Under which of the following conditions does an ideal MOS capacitor substrate lack mobile charge carriers:

Options :

1. ✘ Inversion

2. ✘ Accumulation

3. ✔ Depletion

4. ✘ Reverse bias

Question Number : 49 Question Id : 5113467729 Question Type : MCQ Option Shuffling : Yes Display Question Number : Yes  
Single Line Question Option : No Option Orientation : Vertical

Laser action is found in:

Options :

1. ✔ direct band gap semiconductors

2. ✘ indirect band gap semiconductors

3. ✘ germanium

4. ✘ silicon

Question Number : 50 Question Id : 5113467730 Question Type : MCQ Option Shuffling : Yes Display Question Number : Yes  
Single Line Question Option : No Option Orientation : Vertical

Gettering is the process of trapping elements in silicon (semiconductor) occur

Options :

1. ✘ In the oxide layer

2. ✘ Near the channel

3. ✘ Inside source and drain

4. ✔ Near the back side of wafer

Question Number : 51 Question Id : 5113467731 Question Type : MCQ Option Shuffling : Yes Display Question Number : Yes  
Single Line Question Option : No Option Orientation : Vertical

Anti-reflective coating (ARC) is applied on silicon wafer:

Options :

1. ✘ to reduce the shine as shiny surface can affect our eyes

2. ✘ to make photoresist stick to silicon surface properly

3. ✔ to avoid standing wave in photoresist

4. ✘ after applying photoresist and before exposing wafer to light

Question Number : 52 Question Id : 5113467732 Question Type : MCQ Option Shuffling : Yes Display Question Number : Yes  
Single Line Question Option : No Option Orientation : Vertical

For an ideal p-MOSFET with threshold voltage of  $-0.4V$ , which of the following statements is true?

Options :

1. ✘ It has p-type substrate

2. ✓ It has n-type substrate
3. ✗ It is depletion mode MOSFET
4. ✗ It is not possible for silicon substrate

Question Number : 53 Question Id : 5113467733 Question Type : MCQ Option Shuffling : Yes Display Question Number : Yes  
Single Line Question Option : No Option Orientation : Vertical

Let the diode shown below be ideal. Then the current  $I$  and voltage  $V$  are:

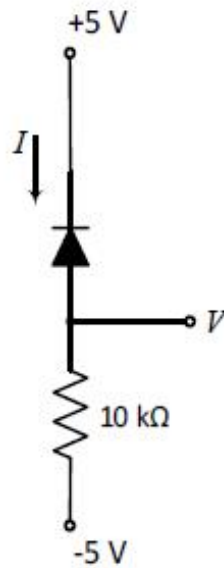

Options :

1. ✗ 0 mA and +5 V
2. ✓ 0 mA and -5 V
3. ✗ 0.5 mA and -5 V
4. ✗ 1 mA and +5 V

Question Number : 54 Question Id : 5113467734 Question Type : MCQ Option Shuffling : Yes Display Question Number : Yes  
Single Line Question Option : No Option Orientation : Vertical

The enhancement-mode MOSFET is also known as:

Options :

1. ✗ p-type MOSFET

2. ✘ n-type MOSFET
3. ✘ normally-on MOSFET
4. ✔ normally-off MOSFET

Question Number : 55 Question Id : 5113467735 Question Type : MCQ Option Shuffling : Yes Display Question Number : Yes  
Single Line Question Option : No Option Orientation : Vertical

Consider a full-wave bridge rectifier fed with a 50 Hz sinusoidal voltage. The lowest ripple frequency at the output of the rectifier will be:

Options :

1. ✘ 50 Hz
2. ✔ 100 Hz
3. ✘ 200 Hz
4. ✘ 400 Hz

Question Number : 56 Question Id : 5113467736 Question Type : MCQ Option Shuffling : Yes Display Question Number : Yes  
Single Line Question Option : No Option Orientation : Vertical

Which of the following statements is not true regarding the ' $\alpha$ ' of a bipolar junction transistor?

Options :

1. ✘ It is the ratio of the change in collector current to the change in emitter current.
2. ✔ It is the ratio of the change in collector current to the change in base current.
3. ✘ It is the current gain in the common-base configuration.
4. ✘ It usually has a value close to unity.

Question Number : 57 Question Id : 5113467737 Question Type : MCQ Option Shuffling : Yes Display Question Number : Yes  
Single Line Question Option : No Option Orientation : Vertical

When both the emitter junction and the collector junction are forward biased, a transistor is said to be operating in:

Options :

1. ✘ active region
2. ✔ saturation region
3. ✘ breakdown region
4. ✘ cut off region

Question Number : 58 Question Id : 5113467738 Question Type : MCQ Option Shuffling : Yes Display Question Number : Yes  
Single Line Question Option : No Option Orientation : Vertical

If an amplifier has a power gain of 100, then its gain in decibels (dB) is:

Options :

1. ✘ 10
2. ✔ 20
3. ✘ 40
4. ✘ 100

Question Number : 59 Question Id : 5113467739 Question Type : MCQ Option Shuffling : Yes Display Question Number : Yes  
Single Line Question Option : No Option Orientation : Vertical

When compared to CE and CC amplifier configurations, a CB amplifier has:

Options :

1. ✘ larger current gain
2. ✘ larger voltage gain
3. ✘ higher input resistance
4. ✔ lower input resistance

Question Number : 60 Question Id : 5113467740 Question Type : MCQ Option Shuffling : Yes Display Question Number : Yes  
Single Line Question Option : No Option Orientation : Vertical

In the circuit shown below, the base current  $I_B$  is  $15 \mu A$ . Assuming that  $\beta = 200$  and  $V_{BE} = 0.7 V$ , the collector-to-emitter voltage  $V_{CE}$  is:

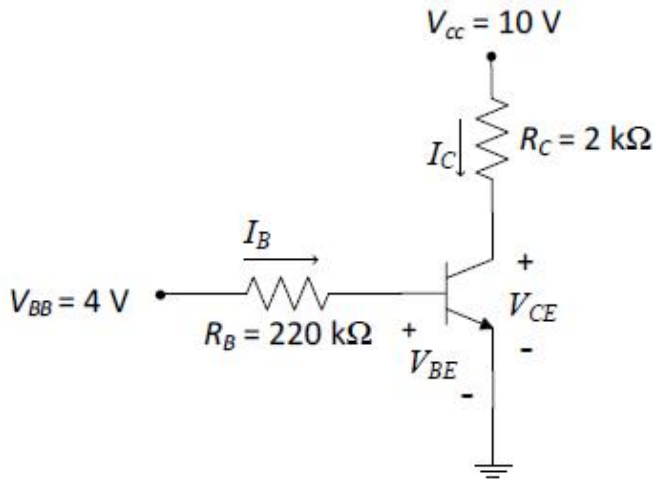

Options :

1. ✘ 2 V
2. ✘ 3 V
3. ✔ 4 V
4. ✘ 5 V

Question Number : 61 Question Id : 5113467741 Question Type : MCQ Option Shuffling : Yes Display Question Number : Yes Single Line Question Option : No Option Orientation : Vertical

In an amplifier, the frequency response curve falls off in the low frequency range due to:

Options :

1. ✘ decreasing impedance of the coupling capacitors
2. ✔ increasing impedance of coupling capacitors
3. ✘ decreasing impedance of shunt capacitors
4. ✘ increasing impedance of shunt capacitors

Question Number : 62 Question Id : 5113467742 Question Type : MCQ Option Shuffling : Yes Display Question Number : Yes Single Line Question Option : No Option Orientation : Vertical

Of the following oscillators, the one which is not an LC-type of oscillator is the:

Options :

1. ✓ Wein-bridge oscillator
2. ✗ Clapp oscillator
3. ✗ Hartley oscillator
4. ✗ Colpitt's oscillator

Question Number : 63 Question Id : 5113467743 Question Type : MCQ Option Shuffling : Yes Display Question Number : Yes  
Single Line Question Option : No Option Orientation : Vertical

The type of noise which occurs in op-amps due to discrete flow of current is:

Options :

1. ✗ flicker noise
2. ✗ thermal noise
3. ✓ shot noise
4. ✗ burst noise

Question Number : 64 Question Id : 5113467744 Question Type : MCQ Option Shuffling : Yes Display Question Number : Yes  
Single Line Question Option : No Option Orientation : Vertical

The op-amp circuit shown below is a/an:

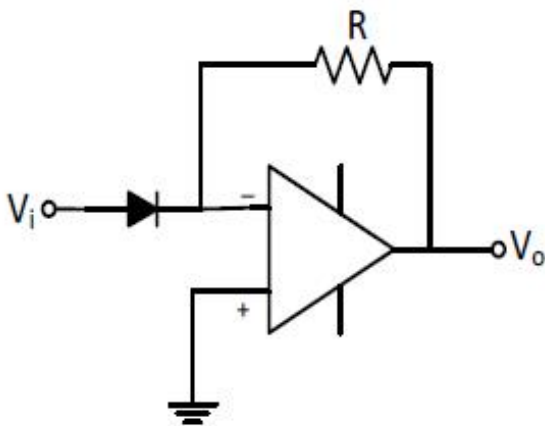

Options :

1. ✗ clipping circuit

2. ✘ clamping circuit

3. ✘ logarithmic amplifier

antilog (or exponential) amplifier

4. ✔

Question Number : 65 Question Id : 5113467745 Question Type : MCQ Option Shuffling : Yes Display Question Number : Yes  
Single Line Question Option : No Option Orientation : Vertical

The op-amp shown in the circuit below has an open-loop voltage gain of  $10^5$  and input offset voltage of 2 mV. The output voltage  $V_{out}$  will be approximately:

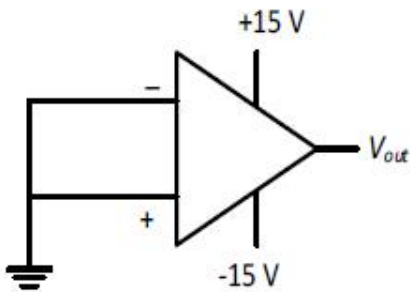

Options :

1. ✘ 0 V

2. ✘ 2 mV

3. ✔ +15 V or -15V

4. ✘ +200 V or -200V

Question Number : 66 Question Id : 5113467746 Question Type : MCQ Option Shuffling : Yes Display Question Number : Yes  
Single Line Question Option : No Option Orientation : Vertical

For minimizing offset voltage error, the value of the bias current compensating resistor  $R_{\text{comp}}$  in the circuit shown below should be:

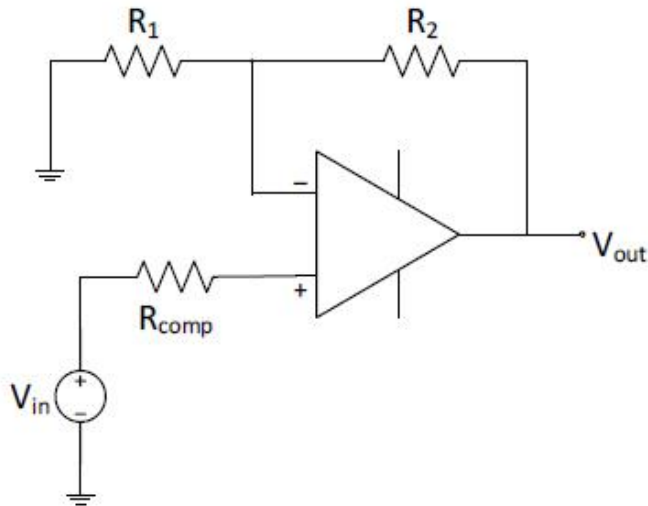

Options :

1. ✘  $R_1$
2. ✘  $R_2/R_1$
3. ✘  $R_1 + R_2$
4. ✔  $\frac{R_1 R_2}{R_1 + R_2}$

Question Number : 67 Question Id : 5113467747 Question Type : MCQ Option Shuffling : Yes Display Question Number : Yes Single Line Question Option : No Option Orientation : Vertical

Two's complement representation of the decimal value (-68) using 8-bit binary format is:

Options :

1. ✘ 01000100
2. ✔ 10111100
3. ✘ 11000100
4. ✘ 00111100

Question Number : 68 Question Id : 5113467748 Question Type : MCQ Option Shuffling : Yes Display Question Number : Yes Single Line Question Option : No Option Orientation : Vertical

The 555-timer circuit shown below is triggered by a negative pulse. Then the width of the output pulse will be:

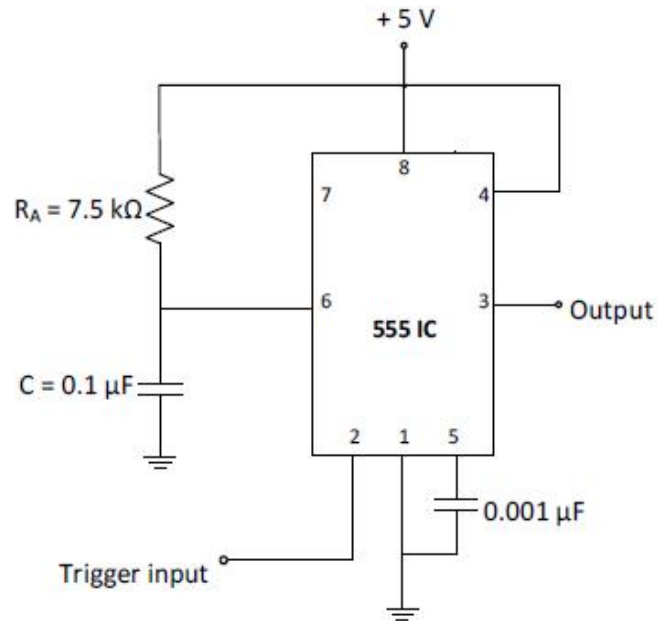

Options :

1. ✘ 0.75 ms
2. ✔ 0.825 ms
3. ✘ 1.15 ms
4. ✘ 7.5 ms

Question Number : 69 Question Id : 5113467749 Question Type : MCQ Option Shuffling : Yes Display Question Number : Yes Single Line Question Option : No Option Orientation : Vertical

A 8-bit shift register is loaded with a data equivalent to  $42_{10}$ . If the contents of the shift register are shifted left (towards MSB) by two bits, the equivalent decimal value would now be:

Options :

1. ✘ 4200
2. ✘ 422
3. ✔ 168
4. ✘ 10

Question Number : 70 Question Id : 5113467750 Question Type : MCQ Option Shuffling : Yes Display Question Number : Yes Single Line Question Option : No Option Orientation : Vertical

The complement of  $\bar{A}B + \bar{C}D$  is:

Options :

1. ✓  $(A + \bar{B})(C + \bar{D})$
2. ✗  $A\bar{B} + C\bar{D}$
3. ✗  $(\bar{A} + B) + (\bar{C} + D)$
4. ✗  $\bar{A}(B + \bar{C})D$

Question Number : 71 Question Id : 5113467751 Question Type : MCQ Option Shuffling : Yes Display Question Number : Yes  
Single Line Question Option : No Option Orientation : Vertical

The reduced Boolean expression for the output of the circuit shown below is:

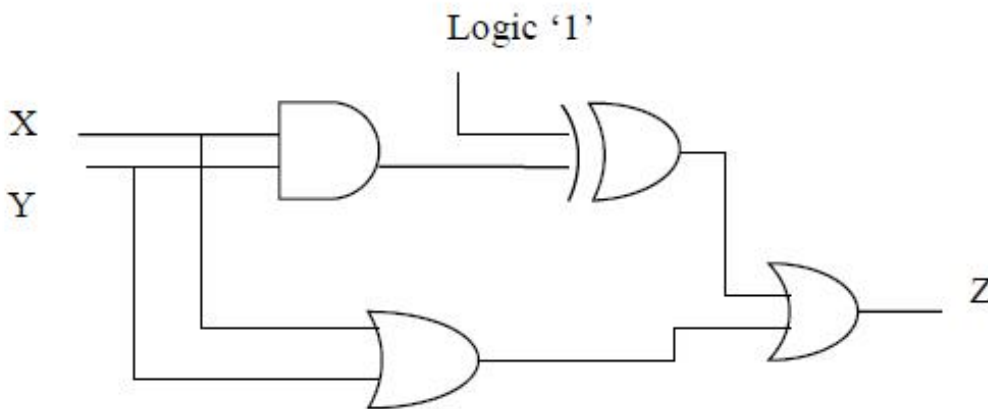

Options :

1. ✗  $Z = XY$
2. ✗  $Z = \bar{X} + \bar{Y}$
3. ✓  $Z = 1$
4. ✗  $Z = 0$

Question Number : 72 Question Id : 5113467752 Question Type : MCQ Option Shuffling : Yes Display Question Number : Yes  
Single Line Question Option : No Option Orientation : Vertical

The reduced SOP form for the Boolean function  $Y(A, B, C, D) = \prod(2, 3, 4, 5, 10, 11, 12, 13)$  is:

Options :

1. ✘  $AB + CD$
2. ✘  $\bar{B}C + B\bar{C}$
3. ✘  $AC + \bar{A}\bar{C}$
4. ✔  $BC + \bar{B}\bar{C}$

Question Number : 73 Question Id : 5113467753 Question Type : MCQ Option Shuffling : Yes Display Question Number : Yes  
Single Line Question Option : No Option Orientation : Vertical

In the 74xx series of TTL devices, the device number of the Quad-2 input NAND gates is:

Options :

1. ✔ 7400
2. ✘ 7486
3. ✘ 7402
4. ✘ 7432

Question Number : 74 Question Id : 5113467754 Question Type : MCQ Option Shuffling : Yes Display Question Number : Yes  
Single Line Question Option : No Option Orientation : Vertical

For the sequential circuit whose state diagram is shown below, assume that the initial state is 'b'.

For an input sequence 1101001, the next state sequence would be:

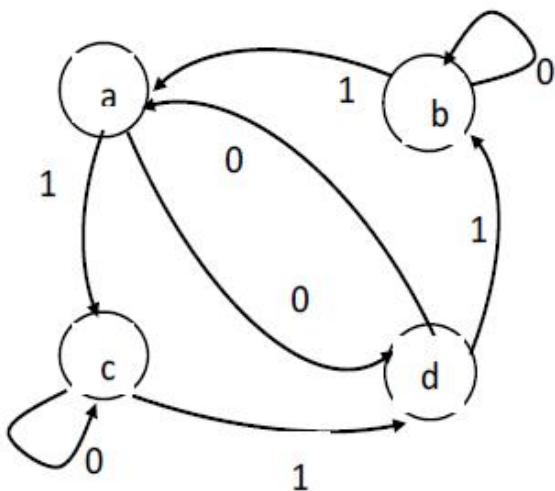

Options :

1. ✔ accdadb

2. ✘ accdbdc
3. ✘ bedcade
4. ✘ dbcaadb

Question Number : 75 Question Id : 5113467755 Question Type : MCQ Option Shuffling : Yes Display Question Number : Yes  
Single Line Question Option : No Option Orientation : Vertical

A 200 kHz clock signal is applied to a JK flip-flop with  $J=1$  and  $K=1$ . The frequency of the output waveform is:

Options :

1. ✘ 50 kHz
2. ✔ 100 kHz
3. ✘ 200 kHz
4. ✘ 400 kHz

Question Number : 76 Question Id : 5113467756 Question Type : MCQ Option Shuffling : Yes Display Question Number : Yes  
Single Line Question Option : No Option Orientation : Vertical

The type of flip-flop which is best suited for synchronous transfer because it requires the least interconnections from one flip-flop to the other is:

Options :

1. ✘ T
2. ✔ D
3. ✘ JK
4. ✘ RS

Question Number : 77 Question Id : 5113467757 Question Type : MCQ Option Shuffling : Yes Display Question Number : Yes  
Single Line Question Option : No Option Orientation : Vertical

The minimum number of flip-flops required to obtain a mod-80 counter is:

Options :

1. ✘ 5
2. ✘ 6
3. ✔ 7
4. ✘ 8

Question Number : 78 Question Id : 5113467758 Question Type : MCQ Option Shuffling : Yes Display Question Number : Yes  
Single Line Question Option : No Option Orientation : Vertical

The number of distinct timing signals which can be generated by a 4-bit Johnson counter is

Options :

1. ✘ 4
2. ✔ 8
3. ✘ 15
4. ✘ 16

Question Number : 79 Question Id : 5113467759 Question Type : MCQ Option Shuffling : Yes Display Question Number : Yes  
Single Line Question Option : No Option Orientation : Vertical

The number of resistor(s) per bit required in a weighted resistor digital-to-analog converter (DAC) is/are:

Options :

1. ✔ 1
2. ✘ 2
3. ✘ 3
4. ✘ 4

Question Number : 80 Question Id : 5113467760 Question Type : MCQ Option Shuffling : Yes Display Question Number : Yes  
Single Line Question Option : No Option Orientation : Vertical

Which of these amplifiers is found in a DAC?

Options :

1. ✓ summer
2. ✗ voltage follower
3. ✗ difference amplifier
4. ✗ non-inverting amplifier

Question Number : 81 Question Id : 5113467761 Question Type : MCQ Option Shuffling : Yes Display Question Number : Yes  
Single Line Question Option : No Option Orientation : Vertical

A memory bank is formed using RAM ICs of size 512x8. The starting address in hexadecimal format of the fifth IC connected in cascade in a memory bank of 4 kB is:

Options :

1. ✗ 03F0
2. ✗ 7800
3. ✓ 0800
4. ✗ 3700

Question Number : 82 Question Id : 5113467762 Question Type : MCQ Option Shuffling : Yes Display Question Number : Yes  
Single Line Question Option : No Option Orientation : Vertical

The 8085 microprocessor is a \_\_\_\_\_ bit \_\_\_\_\_ pin IC:

Options :

1. ✗ 8, 20
2. ✓ 8, 40
3. ✗ 16, 40
4. ✗ 12, 32

Question Number : 83 Question Id : 5113467763 Question Type : MCQ Option Shuffling : Yes Display Question Number : Yes  
Single Line Question Option : No Option Orientation : Vertical

The register pair used for indirect mode of memory addressing is:

Options :

1. ✘ SP
2. ✘ BC
3. ✘ DE
4. ✔ HL

Question Number : 84 Question Id : 5113467764 Question Type : MCQ Option Shuffling : Yes Display Question Number : Yes  
Single Line Question Option : No Option Orientation : Vertical

Among the following, the elements of a rotational motion system are:

Options :

1. ✘ Mass, Spring, Friction
2. ✔ Inertia, Damper, Spring
3. ✘ Work, Energy, Power
4. ✘ Force, Pressure, Viscosity

Question Number : 85 Question Id : 5113467765 Question Type : MCQ Option Shuffling : Yes Display Question Number : Yes  
Single Line Question Option : No Option Orientation : Vertical

The gain of the set up given in the block diagram below is:

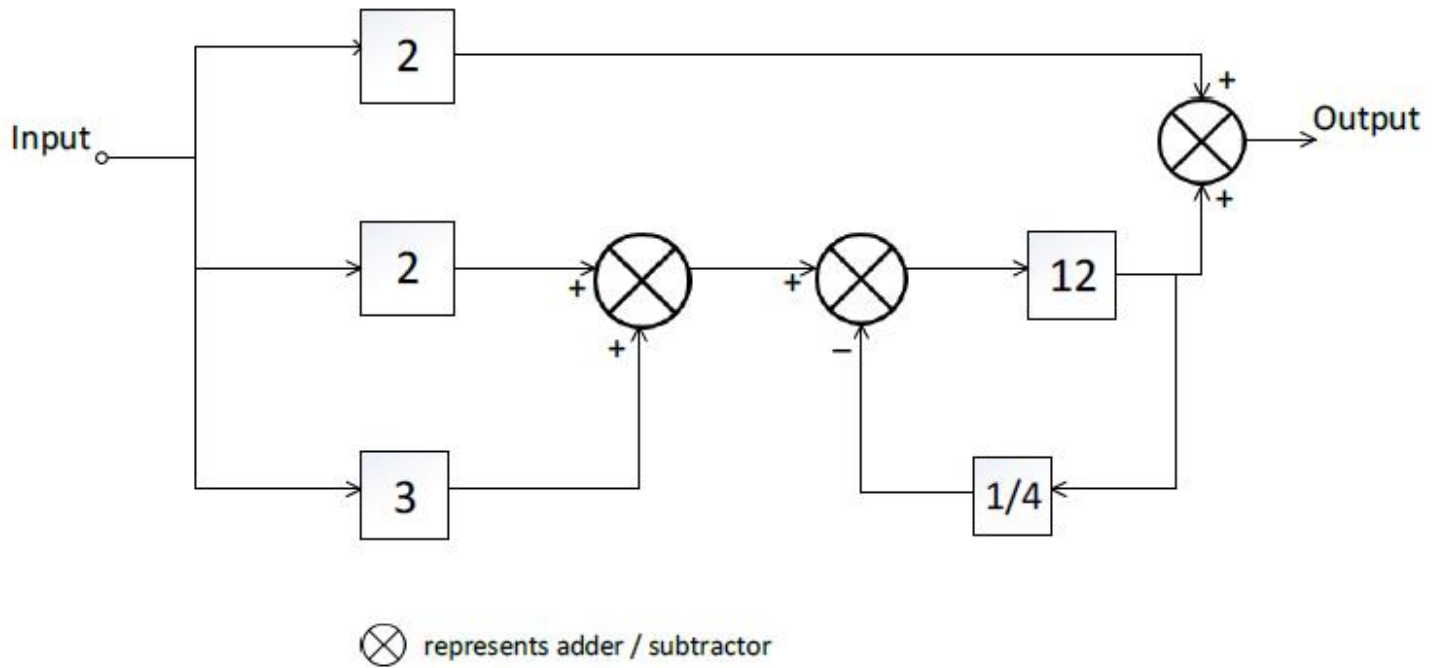

Options :

1. ✗ 36
2. ✗ 13
3. ✓ 17
4. ✗ -10

Question Number : 86 Question Id : 5113467766 Question Type : MCQ Option Shuffling : Yes Display Question Number : Yes  
Single Line Question Option : No Option Orientation : Vertical

For a system with transfer function  $\frac{k}{s(s+2)(s+4)}$ , the breakaway point will be:

Options :

1. ✓ between 0 and -2
2. ✗ between 0 and -4
3. ✗ between -2 and -4
4. ✗ beyond -4

Question Number : 87 Question Id : 5113467767 Question Type : MCQ Option Shuffling : Yes Display Question Number : Yes  
Single Line Question Option : No Option Orientation : Vertical

Consider the unity feedback control system  $G(s) = \frac{10(s+2)}{s^2(s+1)}$ . The type of input which gives a constant steady state error for this system is a/an:

Options :

1. ✘ impulse function
2. ✘ step function
3. ✘ ramp function
4. ✔ parabolic function

Question Number : 88 Question Id : 5113467768 Question Type : MCQ Option Shuffling : Yes Display Question Number : Yes  
Single Line Question Option : No Option Orientation : Vertical

For the second order underdamped system with unit step input, the second overshoot will occur at  $t = \underline{\hspace{2cm}}$ :

Options :

1. ✘  $(2\pi/\omega_d)$
2. ✔  $(3\pi/\omega_d)$
3. ✘  $(4\pi/\omega_d)$
4. ✘  $(5\pi/\omega_d)$

Question Number : 89 Question Id : 5113467769 Question Type : MCQ Option Shuffling : Yes Display Question Number : Yes  
Single Line Question Option : No Option Orientation : Vertical

A second-order unity feedback control system has the closed loop transfer function  $\frac{C(s)}{R(s)} = \frac{2}{s^2+4}$ .

The system is:

Options :

1. ✘ overdamped

2. ✘ underdamped
3. ✔ undamped
4. ✘ critically damped

Question Number : 90 Question Id : 5113467770 Question Type : MCQ Option Shuffling : Yes Display Question Number : Yes  
Single Line Question Option : No Option Orientation : Vertical

Which mechanism in control engineering implies an ability to measure the state by taking measurements at the output:

Options :

1. ✘ Controllability
2. ✔ Observability
3. ✘ Differentiability
4. ✘ Adaptability

Question Number : 91 Question Id : 5113467771 Question Type : MCQ Option Shuffling : Yes Display Question Number : Yes  
Single Line Question Option : No Option Orientation : Vertical

The number of individual loops in the given signal-flow graph below is:

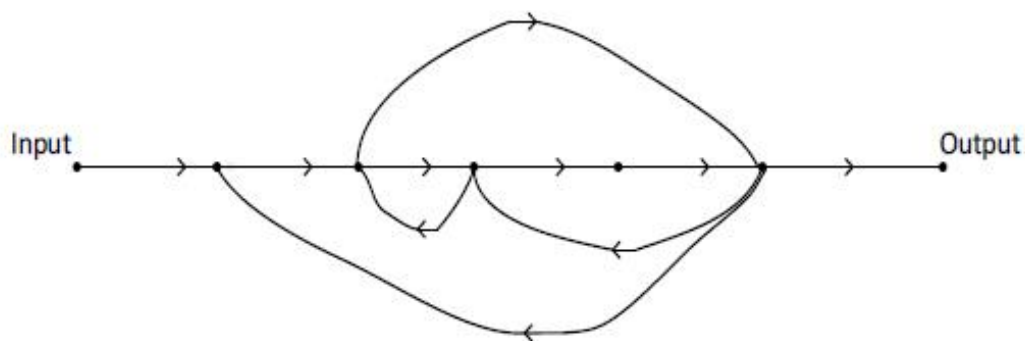

Options :

1. ✔ 4
2. ✘ 5

3. ✘ 3

4. ✘ 2

Question Number : 92 Question Id : 5113467772 Question Type : MCQ Option Shuffling : Yes Display Question Number : Yes  
Single Line Question Option : No Option Orientation : Vertical

If the phase angle at gain crossover frequency is found to be  $-105^\circ$ , the phase margin of the system will be:

Options :

1. ✘  $23^\circ$ 2. ✘  $45^\circ$ 3. ✘  $60^\circ$ 4. ✔  $75^\circ$ 

Question Number : 93 Question Id : 5113467773 Question Type : MCQ Option Shuffling : Yes Display Question Number : Yes  
Single Line Question Option : No Option Orientation : Vertical

In Routh-Hurwitz criterion, if there are changes in sign in the elements of the first column, then the number of sign changes indicates the:

Options :

1. ✘ number of roots with negative real parts

2. ✔ number of roots with positive real parts

3. ✘ number of roots of opposite sign

4. ✘ number of roots of same sign

Question Number : 94 Question Id : 5113467774 Question Type : MCQ Option Shuffling : Yes Display Question Number : Yes  
Single Line Question Option : No Option Orientation : Vertical

A unity feedback system has an open-loop transfer function of  $G(s) = \frac{25(s+4)}{s(s+0.5)(s+2)}$ . The steady state error for unit ramp input is:

Options :

1. ✘ 100
2. ✘ 1
3. ✔ 0.01
4. ✘ 0.001

Question Number : 95 Question Id : 5113467775 Question Type : MCQ Option Shuffling : Yes Display Question Number : Yes  
Single Line Question Option : No Option Orientation : Vertical

On the Bode magnitude plot, the slope of  $1/(1 + j\omega)^2$  for large values of  $\omega$  is:

Options :

1. ✘ -20 dB/decade
2. ✘ +20 dB/decade
3. ✔ -40 dB/decade
4. ✘ +40 dB/decade

Question Number : 96 Question Id : 5113467776 Question Type : MCQ Option Shuffling : Yes Display Question Number : Yes  
Single Line Question Option : No Option Orientation : Vertical

A Gaussian probability function is given by  $p_X(x) = ke^{-x^2/8}$ ,  $-\infty < x < \infty$ . The value of  $k$  should be

Options :

1. ✔  $\frac{1}{2\sqrt{2\pi}}$
2. ✘  $\sqrt{\frac{2}{\pi}}$
3. ✘  $\frac{1}{\pi\sqrt{2}}$

4. ✘  $\frac{1}{\sqrt{2\pi}}$

Question Number : 97 Question Id : 5113467777 Question Type : MCQ Option Shuffling : Yes Display Question Number : Yes  
Single Line Question Option : No Option Orientation : Vertical

A single sideband suppressed carrier signal can be demodulated using:

Options :

1. ✘ a discriminator
2. ✘ an integrator
3. ✔ a synchronous detector
4. ✘ an envelope detector

Question Number : 98 Question Id : 5113467778 Question Type : MCQ Option Shuffling : Yes Display Question Number : Yes  
Single Line Question Option : No Option Orientation : Vertical

An AM transmitter puts out 100 watts with no modulation. With 20% single-tone modulation it will generate:

Options :

1. ✘ 100 watts
2. ✔ 102 watts
3. ✘ 120 watts
4. ✘ 140 watts

Question Number : 99 Question Id : 5113467779 Question Type : MCQ Option Shuffling : Yes Display Question Number : Yes  
Single Line Question Option : No Option Orientation : Vertical

A 5 kHz modulating signal is transmitted as an FM signal with a modulation index of 2. Using Carson's rule, the approximate bandwidth of the FM signal is

Options :

1. ✘ 10 kHz

2. ✘ 14 kHz
3. ✔ 30 kHz
4. ✘ 20 kHz

Question Number : 100 Question Id : 5113467780 Question Type : MCQ Option Shuffling : Yes Display Question Number : Yes  
Single Line Question Option : No Option Orientation : Vertical

FM receivers for the standard 88-108 MHz broadcast band employ an intermediate frequency of

Options :

1. ✘ 455 kHz
2. ✘ 1 MHz
3. ✔ 10.7 MHz
4. ✘ 22.5 MHz

Question Number : 101 Question Id : 5113467781 Question Type : MCQ Option Shuffling : Yes Display Question Number : Yes  
Single Line Question Option : No Option Orientation : Vertical

A broadcast station transmits at a power of 5 kW. The radio channel power attenuation is 10 dB/km. The range of this radio station, if the radio receiver has a sensitivity (i.e., minimum received power required) of 5  $\mu$ W, is

Options :

1. ✔ 9 km
2. ✘ 18 km
3. ✘ 32 km
4. ✘ 50 km

Question Number : 102 Question Id : 5113467782 Question Type : MCQ Option Shuffling : Yes Display Question Number : Yes  
Single Line Question Option : No Option Orientation : Vertical

The entropy of a discrete memoryless source that generates four messages with equal probability is

Options :

1. ✘ 0.25 bit/message
2. ✘ 1 bit/message
3. ✔ 2 bits/message
4. ✘ 4 bits/message

Question Number : 103 Question Id : 5113467783 Question Type : MCQ Option Shuffling : Yes Display Question Number : Yes  
Single Line Question Option : No Option Orientation : Vertical

Consider an AWGN channel of bandwidth  $B$ . Let the channel capacity be  $C$  when operating at a high signal-to-noise power ratio, that is  $\left(\frac{S}{N}\right) \gg 1$ . If  $\frac{S}{N}$  is now quadrupled, that is increased by a factor of 4, keeping  $B$  constant, the new value of channel capacity will be

Options :

1. ✘ unchanged, that is  $C$
2. ✘ approximately  $C + B$
3. ✔ approximately  $C + 2B$
4. ✘ approximately  $C + 4B$

Question Number : 104 Question Id : 5113467784 Question Type : MCQ Option Shuffling : Yes Display Question Number : Yes  
Single Line Question Option : No Option Orientation : Vertical

A baseband message signal having a 5 kHz bandwidth is sampled at twice the Nyquist rate. The time interval between successive samples is

Options :

1. ✔ 50  $\mu\text{s}$
2. ✘ 100  $\mu\text{s}$
3. ✘ 100 ms

4. ✘ 50 ms

Question Number : 105 Question Id : 5113467785 Question Type : MCQ Option Shuffling : Yes Display Question Number : Yes  
Single Line Question Option : No Option Orientation : Vertical

Emphasizing low-level signals and compressing higher-level signals is called

Options :

1. ✔ companding

2. ✘ quantizing

3. ✘ sampling

4. ✘ pre-emphasis

Question Number : 106 Question Id : 5113467786 Question Type : MCQ Option Shuffling : Yes Display Question Number : Yes  
Single Line Question Option : No Option Orientation : Vertical

The Hamming distance between the two code words 10100101 and 01101000 is

Options :

1. ✘ 2

2. ✘ 3

3. ✘ 4

4. ✔ 5

Question Number : 107 Question Id : 5113467787 Question Type : MCQ Option Shuffling : Yes Display Question Number : Yes  
Single Line Question Option : No Option Orientation : Vertical

If the number of bits per sample in a PCM system is increased from  $n$  to  $(n + 2)$ , then the signal-to-quantization noise ratio will improve by approximately

Options :

1. ✘ 2 dB

2. ✘ 3 dB

3. ✘ 6 dB
4. ✔ 12 dB

Question Number : 108 Question Id : 5113467788 Question Type : MCQ Option Shuffling : Yes Display Question Number : Yes Single Line Question Option : No Option Orientation : Vertical

The maximum amplitude of a 1-kHz sinusoidal signal input to a delta modulator that will prevent slope overload, for a step size of 0.1 Volt and sampling frequency of 10,000 samples/sec, is

Options :

1. ✘ 10 Volts
2. ✘ 3.3 Volts
3. ✘  $\pi$  Volts
4. ✔  $\frac{1}{2\pi}$  Volt

Question Number : 109 Question Id : 5113467789 Question Type : MCQ Option Shuffling : Yes Display Question Number : Yes Single Line Question Option : No Option Orientation : Vertical

The bit rate of a 1000 baud 16-QAM signal is

Options :

1. ✘ 16000 bits/sec
2. ✔ 4000 bits/sec
3. ✘ 1000 bits/sec
4. ✘ 250 bits/sec

Question Number : 110 Question Id : 5113467790 Question Type : MCQ Option Shuffling : Yes Display Question Number : Yes Single Line Question Option : No Option Orientation : Vertical

For a bit rate of 16 kbps in a coherent binary FSK scheme, the appropriate values of transmitted frequencies from the choices below, are

Options :

1. ✓ 64 kHz and 80 kHz
2. ✗ 32 kHz and 40 kHz
3. ✗ 40 kHz and 80 kHz
4. ✗ 40 kHz and 64 kHz

Question Number : 111 Question Id : 5113467791 Question Type : MCQ Option Shuffling : Yes Display Question Number : Yes  
Single Line Question Option : No Option Orientation : Vertical

The  $Q$ -function and the complementary error function  $erfc(\cdot)$  are often encountered in bit-error rate (BER) calculations in digital communication. If  $Q(2) = \frac{1}{2} erfc(x)$ , what is  $x$ ?

Options :

1. ✗  $1/2$
2. ✗  $2$
3. ✗  $1/\sqrt{2}$
4. ✓  $\sqrt{2}$

Question Number : 112 Question Id : 5113467792 Question Type : MCQ Option Shuffling : Yes Display Question Number : Yes  
Single Line Question Option : No Option Orientation : Vertical

In CDMA, interference occurs if senders transmit data

Options :

1. ✗ at the same frequency
2. ✗ at the same time
3. ✓ using non-orthogonal codes
4. ✗ using orthogonal codes

Question Number : 113 Question Id : 5113467793 Question Type : MCQ Option Shuffling : Yes Display Question Number : Yes  
Single Line Question Option : No Option Orientation : Vertical

Poynting vector is associated with

Options :

1. ✓ power flow in an electrostatic field
2. ✗ charge in an electrostatic field
3. ✗ flux in a magnetic field
4. ✗ current in an electrostatic field

Question Number : 114 Question Id : 5113467794 Question Type : MCQ Option Shuffling : Yes Display Question Number : Yes  
Single Line Question Option : No Option Orientation : Vertical

The direction of propagation of an electromagnetic wave is obtained from

Options :

1. ✗  $\vec{E}$
2. ✗  $\vec{H}$
3. ✗  $\vec{E} \cdot \vec{H}$
4. ✓  $\vec{E} \times \vec{H}$

Question Number : 115 Question Id : 5113467795 Question Type : MCQ Option Shuffling : Yes Display Question Number : Yes  
Single Line Question Option : No Option Orientation : Vertical

For a medium with permeability  $\mu$  and permittivity  $\epsilon$ , the intrinsic wave impedance is

Options :

1. ✗  $\sqrt{\mu\epsilon}$
2. ✗  $\sqrt{\frac{1}{\mu\epsilon}}$

3. ✓  $\sqrt{\frac{\mu}{\epsilon}}$

4. ✗  $\sqrt{\frac{\epsilon}{\mu}}$

Question Number : 116 Question Id : 5113467796 Question Type : MCQ Option Shuffling : Yes Display Question Number : Yes Single Line Question Option : No Option Orientation : Vertical

For a good conductor, skin depth varies

Options :

1. ✗ directly as  $f$

2. ✗ directly as  $\sqrt{f}$

3. ✗ inversely as  $f$

4. ✓ inversely as  $\sqrt{f}$

Question Number : 117 Question Id : 5113467797 Question Type : MCQ Option Shuffling : Yes Display Question Number : Yes Single Line Question Option : No Option Orientation : Vertical

Consider a lossless transmission line having an inductance  $L$  per unit length and capacitance  $C$  per unit length. The characteristic impedance of the transmission line is

Options :

1. ✓  $Z_0 = \sqrt{\frac{L}{C}}$

2. ✗  $Z_0 = \sqrt{\frac{C}{L}}$

3. ✗  $Z_0 = \sqrt{LC}$

4. ✗  $Z_0 = \frac{1}{\sqrt{LC}}$

Question Number : 118 Question Id : 5113467798 Question Type : MCQ Option Shuffling : Yes Display Question Number : Yes  
Single Line Question Option : No Option Orientation : Vertical

Consider a transmission line that has a characteristic impedance of  $50 \Omega$  and is terminated by a  $25 \Omega$  load. The voltage at the load after a 1-volt pulse starts down this line will be

Options :

1. ✘ a delayed pulse of amplitude  $-4/3$  volts
2. ✘ a delayed pulse of amplitude  $4/3$  volts
3. ✔ a delayed pulse of amplitude  $2/3$  volt
4. ✘ a delayed pulse of amplitude  $1/2$  volt

Question Number : 119 Question Id : 5113467799 Question Type : MCQ Option Shuffling : Yes Display Question Number : Yes  
Single Line Question Option : No Option Orientation : Vertical

A transmission line of any length can be made to simulate an infinite-length line if we

Options :

1. ✘ leave the line open at the end
2. ✘ short the line at the end
3. ✘ increase the standing wave ratio above unity
4. ✔ terminate the line with its characteristic impedance

Question Number : 120 Question Id : 5113467800 Question Type : MCQ Option Shuffling : Yes Display Question Number : Yes  
Single Line Question Option : No Option Orientation : Vertical

Impedance inversion can be obtained using

Options :

1. ✘ a short-circuited stub
2. ✘ an open-circuited stub
3. ✔ a quarter-wave line

4. ✖ a half-wave line