



**Department of School Education
(Pre-University)**

Government of Karnataka

**Revised Question Bank 2024-25
I PUC Electronics**

© Directorate of School Education (Pre-University)

Disclaimer; The question bank is prepared for the benefit of students and teachers. The committee worked for the preparation of question bank made all efforts to make comprehensive and foolproof. However, if any mistakes, errors found, please mail at puebnewrevisedqb@gmail.com, academic.pue@gmail.com.

Copyrights; The copyrights of the question bank lies with the Director, Department of School Education (Pre-University). The question bank is prepared for academic purpose only. No part of the question bank is allowed to use for commercial gains.

Question Bank Development Committee Electronics (40)	
Coordinator	Shivashankar K Senior Grade Lecturer Department of Electronics Govt PU College for Girls Vani Vilas Institute, Fort, Bangalore - 560 002 shankarvanivilas@gmail.com
Member	Savitha R Senior Grade Lecturer Department of Electronics Vidya Mandir Independent PU College, 11 th Cross Malleswaram, Bangalore 560 012 savitha.vijay.19@gmail.com
Member	Malleswara M Senior Grade Lecturer Department of Electronics Nutana Vidyalaya PU College, Kalburgi. malleshwara1973@gmail.com
Member	T S Satish Kumar Senior Grade Lecturer Department of Electronics Hymamshu Composite PU College, 4 th Main Malleswaram, Bangalore 560 055 satish@hymamshu.org
Member	Seema Milind Mahajan Senior Grade Lecturer Department of Electronics SSMRV PU College, No 17, 26 th Main, 36 th Cross, 4 th East T Block, Jayanagar, Bangalore 560 041 seemamilind.ssmrvpu@rvei.edu.in

Contents

Sl. No.	Name of the Chapter	Page no
1	Introduction to Electronics	1
2	Principles of electricity, Network theorems and AC principles	5
3	Measuring instruments	15
4	Passive electronic components	18
5	Applications of DC and AC to passive components	28
6	Semiconductors, Diodes and Applications of diodes	35
7	Bipolar junction transistor	46
8	Introduction to digital electronics	52
9	Practical electronic components, their specifications and PCB	60
10	Blueprint for Model Question Papers	63
11	Model Question Paper 1	64
12	Model Question Paper 2	67
13	Model Question Paper 3	70

Chapter 1

Introduction to Electronics

Choose the correct answer:

1.	The field of science and engineering, which deals with electron devices and their utilization is referred as (a) Electronics (b) Mechanics (c) Photonics (d) Mechatronics (a) Electronics
2.	Vacuum tube triode was invented by (a) J A Fleming (b) J J Thomson (c) Lee De Forest (d) Shockley (c) Lee De Forest
3.	Identify electrodes of a triode (a) Anode (b) Cathode (c) Grid (d) All of these (d) All of these
4.	Transistor was discovered by (a) Bardeen (b) Brattain (c) Shockley (d) All of these (d) All of these
5.	MOSFET stands for (a) Metal oxide semiconductor field effect transistor (b) Metal oxide superconductor field effect transistor (c) Mixed oxide semiconductor field effect triode (d) Metal oxide semiconductor field effect thyristor (a) Metal oxide semiconductor field effect transistor
6.	Identify power device (a) SCR (b) TRIAC (c) MOSFET (d) All of these (d) All of these
7.	SCR stands for (a) Silicon controlled Rectifier (b) Super controlled Rectifier (c) Secondary controlled Resistor (d) Simple controlled Rectifier (a) Silicon Controlled Rectifier
8.	IGBT stands for (a) Insulated Gate Bipolar Transistor (b) Insulated Gate Base Transistor (c) Induction Gate Bipolar Transformer (d) Induction Gate Bipolar Thermistor (a) Insulated Gate Bipolar Transistor
9.	The circuit which converts DC to DC is called (a) Voltage controller (b) Rectifier (c) Chopper (d) Inverter (c) Chopper
10.	The circuit which converts DC to AC is called (a) Voltage controller (b) Rectifier (c) Chopper (d) Inverter (d) Inverter
11.	VLSI stands for (a) Very Large Scale Integration (b) Very Long Scale Integration (c) Very Large Small Integration (d) Very Large Simple Integration (a) Very Large Scale Integration
12.	A microcontroller contains (a) CPU, RAM, ROM (b) I/O ports, timers, counters (c) A/D, D/A, Interrupt controls (d) all of these (d) all of these

13.	RAM stands for (a) Remember Access Memory (b) Read Access Memory (c) Rapid Access Memory (d) Random Access Memory (d) Random Access Memory
14.	ROM stands for (a) Recovery Over Memory (b) Regular Off Memory (c) Read Only Memory (c) Read Over Memory (c) Read Only Memory
15.	Identify the electronics equipment used for entertainment. (a) Radio (b) Television (c) Computer (d) all of these (d) all of these
16.	Internet is used to (a) send email (b) make phone calls (c) video conferencing (d) all of these (d) all of these
17.	Identify the electronics equipment used for defense. (a) Radar (b) Infrared system (c) Submarines (d) all of these (d) all of these
18.	Identify the electronics equipment used in medical field. (a) ECG (b) X-ray (c) Ultra sound scanner (d) all of these (d) all of these

Fill in the blanks:

1.	Study of flow of electrons through vacuum or gas or semiconductor is known as electronics
2.	Electron was discovered by J J Thomson
3.	In Digital Electronics the signals take only different levels. two
4.	Vacuum tube diode was developed by J A Fleming
5.	A triode valve has active electrodes. three
6. is the most commonly used semiconductor material in device fabrication. Silicon
7. proposed JFET. Shockley
8.	The circuit which converts AC to AC is called voltage controller
9.	The circuit which converts AC to DC is called rectifier
10. become workhorse in analog signal processing. Operational amplifier
11.	Concept of integrated circuit (IC) was given by..... Jack Kilby
12.	An entire electronic circuit on a single chip is called integrated circuit
13.	In microprocessor, the input output ports and memories must be interfaced externally
14.	Optical fiber cables are used to send information with the rays. light

One mark questions (Knowledge):

1. What is Electronics?
2. Who discovered electron?
3. Who invented vacuum tube triode?
4. Who invented integrated circuits?
5. Who invented BJT?
6. Who invented JFET?
7. Expand MOSFET.
8. What is a chopper?
9. Expand OP–AMP.
10. Expand TTL.
11. Expand SCR.
12. Expand IGBT.
13. Expand VLSI.
14. Expand EPROM.
15. Expand GPS.
16. Expand WAN.
17. Expand LED.
18. What is internet?

One mark questions (Understanding):

1. How many electrodes are present in vacuum tube triode?
2. Name the electronic device which has replaced the bulky vacuum triode.
3. Name two semiconductor materials used in electronic device fabrication.
4. What is the function of inverter circuit?
5. Name the most commonly used semiconductor material in electronic device fabrications.
6. Name the first four-bit microcontroller developed by Texas Instruments.
7. Name the electronic system used to trace the vehicles from the distant places.

One mark questions (Application):

1. Name any one application of Op–Amp.
2. Where do we use inverters?
3. Where do we use rectifiers?
4. Where do we use microcontrollers?
5. Write one application of GPS.

Two marks questions (Knowledge):

1. Name any four power semiconductor devices.
2. Write a note on role of electronics in our day to day life.
3. Name any two medical electronic equipments.
4. List any four house hold electronic equipments.

Two marks questions (Understanding):

1. Distinguish between microprocessor and microcontroller.
2. Briefly explain how electronics has given us pleasant comforts.
3. Why are semiconductor devices preferred over vacuum tube devices?
4. Silicon is more preferred than germanium in semiconductor devices fabrication. Justify.

Two marks questions (Application):

1. Mention few applications of internet.
2. Mention any two applications of electronics in entertainment.

Three marks questions (Knowledge):

1. Give a brief note on scope of electronics.
2. Write a note on role of electronics in medical science.
3. Discuss on the job opportunities available in the field of electronics.

Three marks questions (Understanding):

1. List the scale of integrations depending on number of components used in IC fabrications.
2. What is the impact of electronics in our daily life?

Three marks questions (Application):

1. Write the applications of electronics in medicine and industry.
2. Write the applications of electronics in defence and communication.
3. Write any six advantages of internet.

Chapter 2

Principles of Electricity, Network Theorems and AC principles

Choose the correct answer:

1.	SI unit of electric charge is (a) Coulomb (b) Watt (c) Joule (d) Ohm (a) Coulomb
2.	The magnitude of a charge is (a) $1.6 \times 10^{-10}C$ (b) $1.6 \times 10^{-19}C$ (c) $1.6 \times 10^{-90}C$ (d) $1.6 \times 10^{-9}C$ (b) $1.6 \times 10^{-19}C$
3.	The SI unit of electric current is (a) Joule (b) Volt (c) Ampere (d) Watt (a) Ampere
4.	The SI unit of electric power is (a) Joule (b) Volt (c) Ohm (d) Watt (d) Watt
5.	While transmitting AC there is energy loss. (a) maximum (b) minimum (c) zero (d) infinite (b) minimum
6.	The frequency of DC is (a) 100 Hz (b) 50 Hz (c) 0 Hz (d) 60 Hz (c) 0 Hz
7.	Ohm's law is not applicable (a) when physical condition of conductor is subjected to change (b) at extreme high and low temperature (c) for nonlinear devices (d) all of these (d) all of these
8.	When 'n' number of resistors each having resistance 'R' are connected in parallel, then the effective resistance is equal to (a) R (b) R/n (c) nR (d) n/R (b) R/n
9.	The rate of doing work is called (a) Electric power (b) Electric current (c) Electric energy (d) none of these (a) Electric power
10.	The total amount of power supplied (or) consumed in certain duration of time is called (a) Electric power (b) Electric current (c) Electric energy (d) none of these (c) Electric energy
11.	1 kWh is equal to (a) $3.6 \times 10^6 J$ (b) $3.6 \times 10^{10} J$ (c) $3.6 \times 10^{60} J$ (d) $3.6 \times 10^{16} J$ (a) $3.6 \times 10^6 J$
12.	An ideal current source has (a) zero internal resistance (b) infinite internal resistance (c) low internal resistance (d) high internal resistance (b) infinite internal resistance

13.	An ideal voltage source has (a) zero internal resistance (b) infinite internal resistance (c) low internal resistance (d) high internal resistance (a) zero internal resistance
14.	A practical current source should have (a) zero internal resistance (b) infinite internal resistance (c) low internal resistance (d) high internal resistance (d) high internal resistance
15.	A practical voltage source should have (a) zero internal resistance (b) infinite internal resistance (c) low internal resistance (d) high internal resistance (c) low internal resistance
16.	Current is divided in (a) series branch (b) parallel branch (c) both series and parallel branches (d) None of these (b) parallel branch
17.	Conductive path through which same current flows is called (a) Node (b) Mesh (c) Loop (d) Branch (d) Branch
18.	According to KCL, the algebraic sum of the currents entering a junction is (a) equal to zero (b) greater than zero (c) less than zero (d) equal to current leaving the junction (d) equal to current leaving the junction
19.	According to KVL, the algebraic sum of all IR drops and e.m.f's in a closed loop is (a) equal to zero (b) greater than zero (c) less than zero (d) equal to infinity (a) equal to zero
20.	A load receives maximum power from a source when (a) $R_L = R_{TH}$ (b) $R_L < R_{TH}$ (c) $R_L > R_{TH}$ (d) $R_L \neq R_{TH}$ (a) $R_L = R_{TH}$
21.	The Thevenin's equivalent of a circuit consists of one voltage source with one resistance in (a) series (b) parallel (c) series-parallel (d) none of these (a) series
22.	The SI unit of frequency is (a) Ohm (b) Watt (c) Hertz (d) Joule (c) Hertz
23.	The relation between frequency and time period is (a) $f = \frac{1}{T}$ (b) $f = \frac{V}{T}$ (c) $f = \frac{R}{T}$ (d) $f = \frac{P}{T}$ (a) $f = 1/T$
24.	The relation between RMS value and peak value of AC is (a) $v_{rms} = \frac{V_m}{\sqrt{2}}$ (b) $v_{rms} = \frac{2V_m}{\pi}$ (c) $v_{rms} = \frac{V_m}{2}$ (d) $v_{rms} = \frac{V_m}{\pi}$ (a) $v_{rms} = \frac{V_m}{\sqrt{2}}$
25.	An expression for instantaneous value of AC voltage is (a) $v = V_m \sin \omega t$ (b) $v = V_m \sin 2\pi f t$ (c) $v = V_m \sin \theta$ (d) all of these (d) all of these

Fill in the blanks:

1.	_____ is a property of certain particles which is responsible for electrical force. Charge
2.	The SI unit of electric charge is _____. Coulomb
3.	One coulomb of charge consists of _____ electrons. 6.25×10^{18}
4.	The rate of flow of charge in a conductor is known as _____. electric current
5.	SI unit of potential difference is _____. volt
6.	The direction of conventional electric current is _____ to the direction of flow of electrons. opposite
7.	Current flowing in a conductor is _____ proportional to potential difference across its ends. directly
8.	If two equal resistance are in series then the effective resistance is _____ the single resistance value. twice
9.	_____ is the commercial unit of energy. kWh
10.	Battery is a combination of _____. cells
11.	A device which supplies energy in the form of voltage is called as _____. voltage source
12.	A device which supplies energy in the form of current is called as _____. current source
13.	A point in an electrical network where current divides is called as _____. node
14.	Kirchhoff's current law is called _____ rule node
15.	Kirchhoff's voltage law is called _____ rule loop
16.	Voltage is divided when resistors connected in _____. series
17.	Resistance of short circuit is _____. 0 Ω
18.	Example of non-sinusoidal waveform is _____ wave Square, triangular, sawtooth, rectangular (any one)

One mark questions (Knowledge):

1. Define electric charge.
2. Define electric current.
3. Define potential difference.
4. What are linear devices?
5. Define electric power.
6. Define kWh.
7. What is the commercial or Board Of Trade (BOT) unit of electrical energy?
8. What is the direction of conventional current?
9. What is a node?
10. What is a closed loop?
11. What is an open loop?
12. What is a mesh?
13. Give an expression for instantaneous value of AC voltage.
14. Define RMS value of AC.
15. What is a square wave?

One mark questions (Understanding):

1. How do you relate voltage and current in case of conductors?
2. How many electrons pass through a conductor in one second if the current through the Conductor is one ampere?
3. Can Ohm's law be applicable when the temperature of a conductor continuously changes?
4. How do you arrange cells to get desired current rating?
5. How do you connect cells to obtain desired voltage rating?
6. Give an example for electro-chemical cell.
7. What do you mean by current source?
8. When will a load receive maximum power from a source?
9. Who invented modern alternating current electrical supply system?
10. RMS value has to be considered in case of AC. Why?
11. How much is the AC voltage supplied to all household electrical devices in India?
12. Mention any one type of battery used in mobile phones.

One mark questions (Application):

1. What will be the current flowing through an open circuit?
2. What will be the voltage across short circuit?
3. Write any one application of network theorem.
4. Mention one advantage of superposition theorem.
5. Mention an application of maximum power transfer theorem.
6. The output impedance of an amplifier is 8Ω . What should be the input impedance of the loud speaker to hear the quality sound?

Two marks questions (Knowledge):

1. What is the frequency of DC? Name any one DC source.
2. What is meant by a linear network? Give an example for linear device.
3. What is meant by a nonlinear network? Give an example for nonlinear device.
4. What will be the resistance in open circuit and short circuit?
5. State superposition theorem.
6. State Thevinin's theorem.
7. State KVL and KCL.
8. What are primary DC-sources? Give an example.
9. What are secondary DC-sources? Give an example.
10. Define 'branch' and 'loop' in an electrical circuit?
11. Define peak value and RMS value.
12. Define time period and frequency of AC?
13. Mention the unit of AC voltage and frequency.

Two marks questions (Understanding):

1. Give an example for primary and secondary batteries.
2. Give an example for AC and DC sources.
3. Distinguish between open and short circuit.
4. Write the difference between voltage source and current source.
5. Compare ideal and practical voltage source.
6. What is the difference between conventional current and electron current?
7. Draw the V-I characteristics of a practical voltage source.
8. Why is DC not used for powering all houses?

Two marks questions (Application):

1. A bulb of a car head light is connected to a 12 V battery maintains 3 A of current. What is the power rating of the bulb? [Ans: 36 W]
2. Find the resistance between A and B. [Ans: 1 Ω]

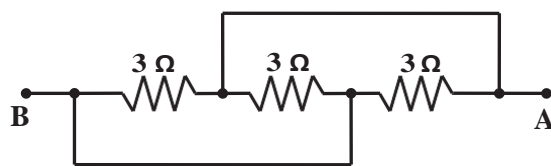

3. Find the current 'I' in the circuit. [Ans: 0.5 A]

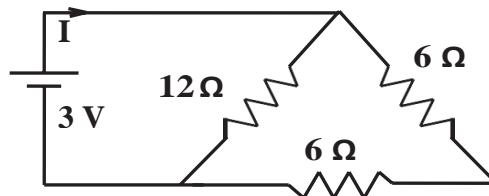

4. The specifications of an iron box are labelled as 230 AC, 350 W. Calculate the resistance of the iron box. [Ans: 151 Ω]
5. A 12 V battery allows 2 A of current through a resistor. What is the current in the same resistor if a 6 V battery is connected? [Ans: 1 A]

6. For the circuit shown below determine

a) Total resistance

[$R_T = 20 \Omega$]

b) Total current flowing in the circuit

[$I = 0.6 \text{ A}$]

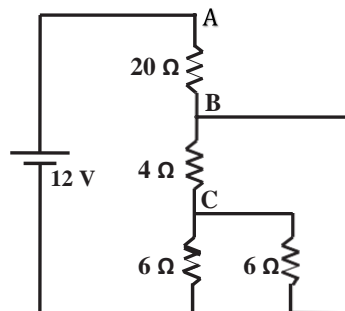

7. Calculate the current I flowing into the node N in the given circuit.

[Ans: -2 mA]

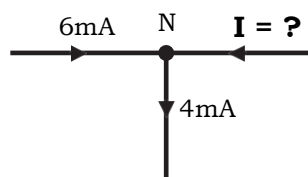

8. The angular frequency of a waveform is 314 Hz .

Find its a) frequency and b) time period.

[Ans: 50 Hz , 20 ms]

9. The equation of an alternating voltage is given by $v = 325\sin(314t)$. Find the frequency and the RMS value of the voltage.

[Ans: 50 Hz , 230 V]

Three marks questions (Knowledge):

1. Mention the properties of charges.
2. Mention any three limitations of Ohm's law.
3. What are primary and secondary batteries? Give an example for each.
4. Define the terms - Mesh, Branch and Loop in an electrical network.
5. Define the following terms in an AC signal
a) Frequency b) Time period c) Peak Value
6. Briefly explain open circuit and short circuit with relevant circuit.

Three marks questions (Understanding):

1. Give comparison between AC and DC.
2. Write any three differences between the Dry cell and Wet cell.
3. How to convert voltage source into current source? Explain.
4. How to convert current source into voltage source? Explain.
5. Find the number of branches, nodes and loops in the following circuit

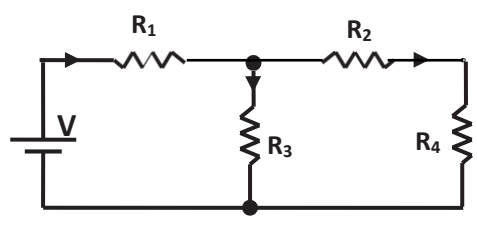

6. Explain voltage divider rule.
7. Explain current divider rule.
8. Draw any three non-sinusoidal waveforms.

Three marks questions (Application):

1. A battery is connected across a conductor. If it transfers 30 C of charge and the amount of work done by the battery is 90 joules, what is the battery voltage? [Ans: 3 V]
2. How do you create 3 V, 2 V and 1 V from a 3 V source?
3. An UPS supplies 2 A of current to a bulb of 20 V for 20 minutes. Calculate the amount of charge supplied by the UPS. [Ans: 2400 C]
4. Find the total resistance between A and B. [Ans: 0.75 Ω]

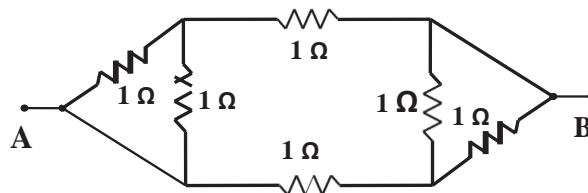

5. Find the total current flowing in the circuit also find the branch current? [Ans: $I = 1$ A, $I_1 = 0.75$ A, and $I_2 = 0.25$ A]

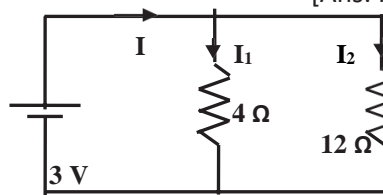

6. Find the current flowing through and voltage across R using super position theorem. [Ans: $V = 6$ V, $I = -3$ A]

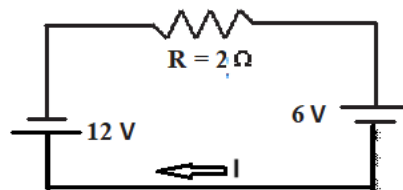

7. Find the total current and total resistance in the circuit given below. [Ans: $I_{tot} = 1$ A, $R_t = 10$ Ω]

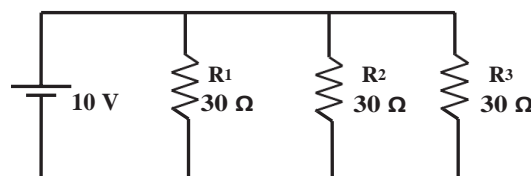

8. A 220 Ω resistor is connected to 230 V sinusoidal 50 Hz supply. Find the peak, rms and average values of the current and the power dissipated. [Ans: $V_p = 335$ V, $V_{rms} = 230$ V, $V_{avg} = 207$ V]

9. Find the total current flowing in the circuit. Also find the branch current?

[Ans: $I = 1.2 \text{ mA}$, $I_1 = I_2 = 0.6 \text{ mA}$]

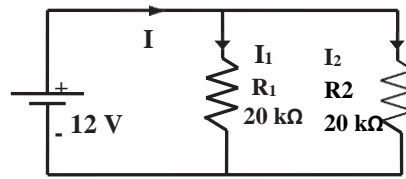

10. Find the following in the given circuit.

(a) Voltage at A

(b) Potential at B

(c) Total current flowing in the circuit

[Ans: $V_A = 6 \text{ V}$, $V_B = 0 \text{ V}$, $I = 3 \text{ mA}$]

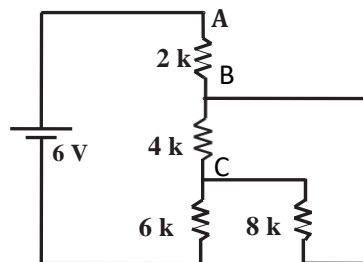

11. A sinusoidal voltage varies from zero to a maximum value of 200 V. How much is its value at the instances of a) 30° b) 45° c) 90°

[Ans: (a) 100 V (b) 141 V (c) 200 V]

12. Find V_m , V_{p-p} , and frequency of the given waveform.

[$V_m = 2 \text{ V}$, $V_{p-p} = 4 \text{ V}$, $f = 25 \text{ Hz}$]

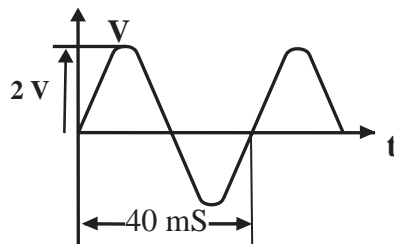

13. A 100 W electric bulb connected across a 230 V, 50 Hz power line. What is the rms and peak value of the current flowing through it?

[Ans: $V_{rms} = 230 \text{ V}$, $I_{rms} = 0.434 \text{ A}$, $I_p = 0.613 \text{ A}$]

Five marks questions (Application):

1. In the figure, determine the unknown branch currents and unknown resistance of resistors.

[Ans: $R_2 = 2.66 \text{ k}\Omega$, $I_3 = 7.5 \text{ mA}$, $I_2 = 2.5 \text{ mA}$, $I_1 = 30 \text{ mA}$]

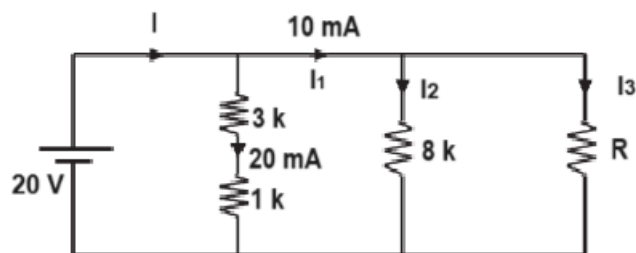

2. Determine the branch currents in the given figure.

[Ans : $I_1 = 0.272 \text{ A}$, $I_2 = 2.18 \text{ A}$, $I_3 = 2.45 \text{ A}$]

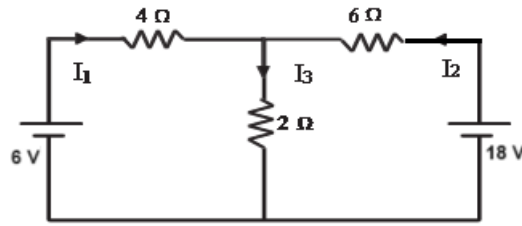

3. Determine the branch currents and voltage drops across each resistor.

[Ans : $I_1 = 0.375 \text{ A}$, $I_2 = 0.187 \text{ A}$, $I_3 = 0.187 \text{ A}$]

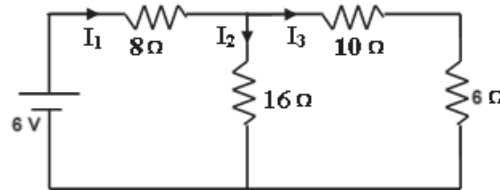

4. Find the total resistance between the terminals O and E in the figure shown below.

[Ans: $R_t = 2.87 \Omega$]

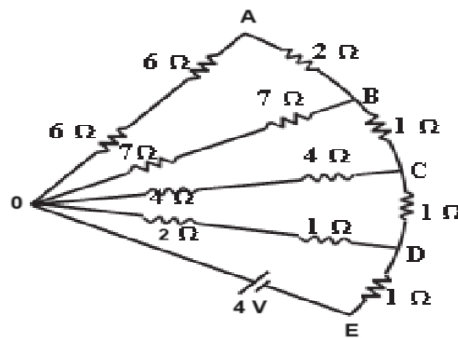

5. Using superposition theorem, find the current through the 20Ω resistance of the circuit.

[Ans: 0.555 A]

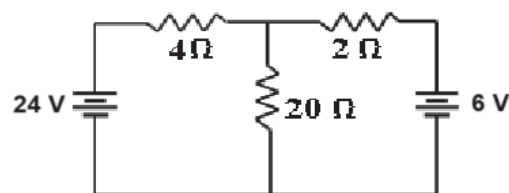

6. What should be the value of load R_L to abstract maximum power from 12 V batteries?
Determine the power transferred to R_L .

[Ans: $R_{th} = R_L = 6.1 \text{ k}\Omega$, $V_{th} = 8.14 \text{ V}$, $P_{max} = 2.71 \text{ mW}$]

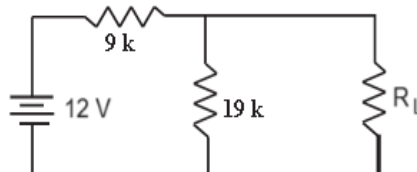

7. Use superposition theorem to find the current through $12\ \Omega$ resistor. [Ans: 1.62 A]

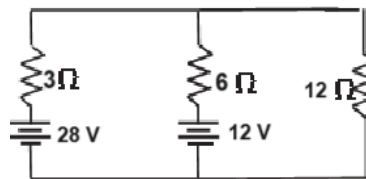

8. According to Maximum Power transfer theorem, what should be the value of load resistance R_L to abstract maximum power from the 16 V battery as shown in figure below? What is the value of maximum power? [Ans: $R_{TH} = 4\ \Omega$, $P_{max} = 1.77\ W$]

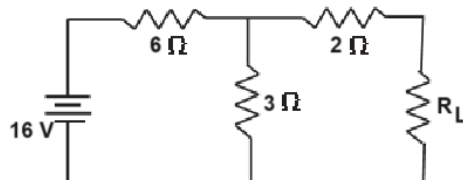

9. Calculate V_m , V_{p-p} , V_{rms} , time period and frequency of the given waveform.

[Ans: $V_p = 3\ V$, $V_{p-p} = 6\ V$, $V_{rms} = 2.1\ V$, $V_{AVG} = 1.91V$, $T = 20\ \mu S$, $f = 50\ kHz$]

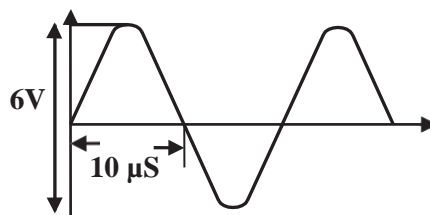

Five marks questions (Knowledge):

1. State and explain KCL and KVL.
2. State and explain Thevenin's theorem with an example.
3. State and explain superposition theorem.
4. Define the following terms with respect to an AC signal
 - a) Cycle
 - b) RMS value
 - c) Peak to peak value
 - d) Average value
 - e) Instantaneous voltage.

Five marks questions (Understanding):

1. Distinguish between DC and AC.
2. Derive an expression for the effective resistance of two resistors connected in series.
3. Derive an expression for the effective resistance of two resistors connected in parallel.
4. State and explain maximum power transfer theorem with an example

Chapter 3

Measuring Instruments

Choose the correct answer:

1.	An instrument which is used to measure voltage between two nodes is (a) Ohmmeter (b) voltmeter (c) ammeter (d) glucometer (b) voltmeter
2.	CRO stands for (a) Carrier Ray Oscillator (b) Cathode Ray Oscilloscope (c) Common Radio Oscilloscope (d) Cathode Radar Oximeter (b) Cathode Ray Oscilloscope
3.	CRO can be used to measure (a) AC voltage (b) DC voltage (c) Frequency (d) Any of these (d) Any of these
4.	An ECG is used to predict the function of (a) brain (b) heart (c) liver (d) kidney (b) heart
5.	ECG stands for (a) Electrocardiogram (b) Electroncardiogram (c) Echocardiogram (d) emissioncardiogram (a) Electrocardiogram
6.	A medical test that capture live images from the inside of human body is (a) Thermometer (b) pulse oximeter (c) ultrasound scan (d) Ohmmeter (c) ultrasound scan
7.	A medical test instrument used to measure the oxygen level in the blood is (a) Thermometer (b) pulse oximeter (c) ultrasound scan (d) Ohmmeter (b) pulse oximeter

Fill in the blanks:

1.	Transducer convert physical quantity into _____ signal electrical
2.	An instrument which is used to measure electric current in a circuit is _____ Ammeter
3.	An instrument which is used to measure electrical resistance is _____ Ohmmeter
4.	Measuring instrument that can measure voltage, current, resistance is _____ Multimeter
5.	An instrument used to display the electric signal is _____ CRO
6.	A medical instrument used to measure blood pressure is _____ sphygmomanometer
7.	An instrument used for measuring the temperature of body is _____ Thermometer
8.	Instrument used to measure glucose present in the blood is _____ glucometer

One mark questions (Knowledge):

1. What is an oscilloscope?
2. What is ECG?
3. What is sphygmomanometer?
4. Name the meter which is used to measure glucose present in human body?
5. What is a pulse oximeter?

One mark questions (Understanding):

1. How do you connect an ammeter in a circuit?
2. How do you connect the voltmeter in a circuit?
3. Name the instrument which measures resistance.
4. Name the instrument which is used to measure current, voltage, resistance, etc.
5. Which instrument is used to measure the arterial blood pressure?

One mark questions (Application):

1. Can we check correctness of a diode using multimeter?
2. Is it possible to measure DC of 10 mV using CRO?
3. Write any one application of ECG.
4. Mention one application of Glucometer.
5. Mention one application of pulse oximeter.

Two marks questions (Knowledge):

1. Write the merits of multimeter.
2. Write the symbol of AC ammeter and DC Voltmeter.
3. Write the two important elements of a digital thermometer.
4. Explain the controls of multimeter.
5. Mention any four controls of CRO.

Two marks questions (Understanding):

1. Give an example for signal conditioner and transducer.
2. How does digital thermometer work?

Two marks questions (Application):

1. What is CRO? Mention few applications of CRO.
2. What are the applications of glucometer and pulse oximeter?

Three marks questions (Knowledge):

1. Write the block diagram showing essential parts of electronic measuring instrument.
2. Explain Ohm meter.
3. List the precautions while using electronic instruments.

Three marks questions (Understanding):

1. Give details of various controls of multimeter.
2. Give details of front panel controls of CRO.
3. How DC voltage is measured using CRO?
4. Mention any three bio-medical electronic devices.

Three marks questions (Applications):

1. Explain how AC voltage, time period and frequency measured using CRO.
2. Write applications of multimeter.
3. Determine time period and frequency of AC. Given distance between two successive peaks on CRO screen is 4.0 divisions and time/division = 2 ms/division. Ans: $T = 8 \text{ ms}$, $f = 125 \text{ Hz}$
4. Determine peak voltage and rms voltage of AC. Given height of the trace from peak to peak on CRO screen is 4.0 divisions and volts/division = 5 V/division.

Ans: $V_p = 10 \text{ V}$, $V_{rms} = 7.07 \text{ V}$

Chapter 4

Passive electronic components

Choose the correct answer

1.	Passive electronic components (a) absorb energy (b) store energy (c) dissipate energy (d) all of these (d) all of these
2.	Examples for passive electronic components are (a) Resistor (b) Capacitor (c) Inductor (d) all of these (d) all of these
3.	Examples for active electronic components are (a) Diode (b) LED (c) Transistor (d) all of these (d) all of these
4.	Identify the active device amongst the following (a) Resistor (b) Capacitor (c) Inductor (d) Transistor (d) Transistor
5.	A resistor is used to (a) limit current (b) divide voltage (c) dissipate energy (d) all of these (d) all of these
6.	The change in resistance per degree rise in temperature to its resistance at 0° C is termed as (a) light coefficient of resistance (b) temperature coefficient of resistance (c) heat coefficient of resistance (d) none of these (b) temperature coefficient of resistance
7.	The fourth band of CFR resistor indicates the (a) tolerance (b) multiplier (c) wattage (d) power rating (a) tolerance
8.	The third color band of CFR resistor indicates the (a) tolerance (b) multiplier (c) wattage (d) power rating (b) multiplier
9.	When there are only three color bands on the resistor, the tolerance is (a) ±0% (b) ±5% (c) ±10% (d) ±20% (d) ±20%
10.	The third color band of 33 kΩ resistor has (a) red (b) orange (c) yellow (d) green (b) orange
11.	A very small rectangular shaped metal oxide film resistor is (a) PTC resistor (b) NTC resistor (c) SMD resistor (d) none of these (c) SMD resistor
12.	The resistance value of SMD resistor with code '223' is (a) 22 Ω (b) 220 Ω (c) 2.2 kΩ (d) 22 kΩ (d) 22 kΩ
13.	The value of resistance of a resistor having color bands yellow-violet-red-silver is (a) 4.7 Ω ±10% (b) 47 Ω ±10% (c) 470 Ω ±10% (d) 4.7 kΩ ±10%

	(b) 4.7 kΩ ±10%
14.	For 2.2 kΩ resistor with ±5% tolerance, the color bands will be in the sequence (a) Red-Red-Red-Silver (b) Red-Red-Red-Gold (c) Orange-Orange-Red-Silver (d) Orange-Orange-Red-No colour (b) Red-Red-Red-Gold
15.	The charge storage ability of a capacitor is called its (a) capacitance (b) resistance (c) conductance (d) resistivity (a) capacitance
16.	The purpose of the dielectric material in a capacitor is to (a) increase the size (b) enhance physical strength (c) increase capacitance (d) decrease capacitance (c) increase capacitance
17.	The capacitance value of a capacitor depends upon (a) distance between the plates (b) area of the plates (c) nature of the dielectric used (d) all of these (d) all of these
18.	In a capacitor, the permittivity ϵ is given by (a) ϵ_0 (b) ϵ_r/ϵ_0 (c) $\epsilon_0\epsilon_r$ (d) ϵ_0/ϵ_r (c) $\epsilon_0\epsilon_r$
19.	The energy stored E in a capacitor is given by (a) $E = \frac{1}{2}CV^2$ (b) $E = \frac{1}{2}VC^2$ (c) $E = \frac{1}{2}CV$ (d) $E = \frac{1}{2}C^2V^2$ (a) $E = \frac{1}{2}CV^2$
20.	Energy stored in a capacitor of 1 μF connected to 10 V DC. (a) 0.50 μJ (b) 5.0 μJ (c) 50 μJ (d) 500 μJ (c) 50 μJ
21.	A capacitor blocks (a) AC (b) DC (c) both DC and AC (d) Neither AC nor DC (b) DC
22.	For DC, capacitor acts like (a) open circuit (b) short circuit (c) closed circuit (d) none of these (a) open circuit
23.	When capacitors are connected in parallel combination, the effective capacitance (a) remains constant (b) increases (c) decreases (d) none of these (b) increases
24.	When capacitors are connected in series combination, the effective capacitance (a) remains constant (b) increases (c) decreases (d) none of these (c) decreases
25.	Two capacitors of having equal capacitance 'C' connected in series, the effective capacitance is (a) C (b) C/2 (c) 2C (d) 2/C (b) C/2
26.	The relationship between charge (Q), voltage (V) and capacitance (C) is (a) $C = \frac{V}{Q}$ (b) $C = \frac{Q}{V}$ (c) $C = QV$ (d) $C = Q^2V$

	(b) $C = \frac{Q}{V}$
27.	Phenomenon of producing electricity using magnetism is called (a) electromagnetic induction (b) electrostatics (c) thermodynamics (d) none of these (a) electromagnetic induction
28.	The phenomenon of producing induced e.m.f and hence induced current in a coil by changing magnetic flux in the same coil itself is called (a) self-induction (b) mutual induction (c) rectification (d) none of these (a) self-induction
29.	The phenomenon of producing e.m.f in the secondary coil by changing current in the primary coil is called (a) self-induction (b) mutual induction (c) rectification (d) none of these (b) mutual induction
30.	A passive electronic component that stores energy in the form of a magnetic field is (a) resistor (b) capacitor (c) inductor (d) thermistor (c) inductor
31.	The unit of inductance is (a) Henry (b) Farad (c) Ampere (d) Hertz (a) Henry
32.	An expression for energy stored E in an inductor is (a) $E = \frac{1}{2} L I^2$ (b) $E = \frac{1}{2} L^2 I^2$ (c) $E = \frac{1}{2} L I$ (d) $E = \frac{1}{2} \sqrt{L I}$ (a) $E = \frac{1}{2} L I^2$
33.	An inductor opposes (a) change in current (b) change in voltage (c) change in electric field (d) none of these (a) change in current
34.	The inductance value of an inductor depends upon (a) the number of turns in the coil (b) length of the coil (c) cross section area of the coil (d) all of these (d) all of these
35.	A transformer is an electrical device used to (a) step up and step down voltage (b) isolate output from input circuit (c) transfer electrical energy mutually (d) all of these (d) all of these
36.	The ratio of the output power to the input power of a transformer is called transformer (a) efficiency (b) turns ratio (c) current ratio (d) voltage ratio (a) efficiency
37.	The following parameter does not change at input and output of a transformer (a) current (b) voltage (c) frequency (d) all of these (c) frequency
38.	The relation between turns ratio, voltage ratio and current ratio in a transformer is (a) $\frac{V_S}{V_P} = \frac{N_S}{N_P} = \frac{I_P}{I_S}$ (b) $\frac{I_S}{I_P} \neq \frac{V_S}{V_P} = \frac{N_S}{I_S}$ (c) $\frac{I_S}{I_P} = \frac{I_S}{V_P} = \frac{N_S}{I_S}$ (d) $\frac{I_S}{I_P} = \frac{V_S}{V_P} = \frac{V_S}{I_S}$

	(a) $\frac{V_S}{V_P} = \frac{N_S}{N_P} = \frac{I_P}{I_S}$
39.	In a step-up transformer, (a) current is stepped down (b) current is stepped up (c) current remains same (d) none of these (a) current is stepped down
40.	Carbon microphone is an example of (a) Resistor (b) Capacitor (c) Inductor (d) transducer (d) transducer

Fill in the Blanks:

1.	Active components _____ energy to the circuit. supply
2.	Ability of a resistor to oppose current is called _____. resistance
3.	The percentage variation in resistance w.r.t. marked values of a resistor is termed as _____. tolerance
4.	The maximum power a resistor can dissipate safely is called _____ rating of the resistor. power
5.	The SI unit of resistivity or specific resistance is _____. Ωm
6.	At a constant temperature resistance of a conductor is directly proportional to its _____. length
7.	The ease with which a substance allows current to flow through it is called _____. conductance
8.	The reciprocal of resistance is _____. conductance
9.	The unit of conductance is _____. Siemens
10.	The fifth band of a MFR resistor indicates its _____. tolerance
11.	The small rectangular shaped metal oxide film resistor is called as _____. SMD resistor
12.	Wire wound resistors are used in _____. ammeters
13.	Potentiometer is a _____ resistor. variable
14.	Capacitor consists of two conducting _____. plates
15.	_____ a passive electronic component used to store electric charge. Capacitor
16.	The S.I unit of capacitance is _____. Farad

17.	Capacitance of a capacitor is inversely proportional to _____ distance between the plates
18.	Capacitor allows _____ ac
19.	To obtain maximum capacitance value, the given capacitors must be connected in _____ parallel
20.	Capacitor which is sensitive to polarity is _____ electrolytic capacitor
21.	Capacitors in series store same _____ charge
22.	Capacitors in parallel have _____ voltage. same
23.	Important specification of a capacitor is its _____ voltage rating
24.	1 μF is equal to _____ 10^{-6} F
25.	The unit of self-inductance is _____ Henry
26.	When number of inductors are connected in series the effective inductance _____ increases
27.	Transformer works on the principle of _____ mutual induction
28.	The ratio of the number of turns in the secondary coil to the number of turns in the primary coil is termed as _____ turns ratio
29.	A transformer in which $V_S > V_P$ is called as _____ step-up transformer
30.	A transformer in which $V_S < V_P$ is called as _____ step-down transformer
31.	A device which convert one form of energy into another form is known as _____ transducer
32.	A transducer which converts change in pressure into change in electrical signals and vice-versa is called _____ pressure transducer
33.	A transducer which converts electrical signals into sound waves is _____ loud speaker
34.	A transducer which converts sound waves into electrical signals is _____ microphone

One mark questions (Knowledge):

1. What is a passive component?
2. What is an active component?
3. What is a resistor?
4. What is the unit of resistance?
5. What is ohms rating of a resistor?
6. Define temperature coefficient of a resistor.
7. Define specific resistance or resistivity.
8. Write the circuit symbol of variable resistor.
9. Write the circuit symbol of preset.
10. Name any one fixed resistor.
11. Name any one variable resistor.
12. What is a SMD resistor?
13. What is capacitance of a capacitor?
14. What is the unit of capacitance?
15. Write the circuit symbol of inductor.
16. What is electromagnetic induction?
17. What is the unit of self-inductance?
18. Write the circuit symbol of iron core inductor.
19. Write the circuit symbol of air core inductor.
20. Write the expression for energy stored in an inductor.
21. Write the mathematical expression for self-inductance.
22. What is a transformer?
23. Define turns ratio.
24. What is a step down transformer?
25. What is a transducer?
26. What is meant by pressure transducer?

One mark questions (Understanding):

1. Give one example for a passive component.
2. Give one example for an active component.
3. What does the fourth band of 4 band colour coded resistor indicate?
4. What does the fifth band of 5 band colour coded resistor indicate?
5. Write any one advantage of metal film resistor against carbon composition resistor.
6. What does the power rating of a resistor indicate?
7. Which type of capacitor is sensitive to polarity.
8. When is inductance said to be 1 Henry?
9. Which has more inductance, a coil with iron core or with air core?
10. Write the relation between turns ratio, voltage ratio and current ratio in a transformer.
11. Which expression do you use to calculate the effective inductance when two inductors are connected in series?
12. Write the expression for the effective inductance when two inductors are connected in parallel.

13. Write the unit for energy stored in an inductor?
14. Which type of inductor is used in radio frequency range?
15. What happens to the strength of secondary current with reference to primary current in a step down transformer?
16. Which principle of inductance is used in transformer?

One mark questions (Application):

1. Draw the symbol of electrolytic capacitor.
2. What would be the current value in a capacitor when it is fully charged by DC-source?
3. How do you connect number of capacitors to obtain maximum capacitance value?
4. How do you connect number of capacitors to obtain minimum capacitance value?
5. Write the application of a speaker.
6. What is the resistance of a resistor when shorted?
7. What is the resistance of a capacitor when shorted?
8. What is the resistance of a resistor when open?
9. What is the resistance of a capacitor when open?
10. What is the resistance value of SMD resistor printed with the code 223? Ans: 22 k Ω

Two marks questions (Knowledge):

1. Write any two specifications of resistor.
2. What are the factors on which resistance of the material depends?
3. Mention the factors on which the capacitance of a capacitor depends.
4. Write an expression for energy stored in a capacitor.
5. What is leakage current and leakage resistance in a capacitor?
6. Write any two specifications of an inductor.
7. List the factors on which self-inductance of a coil depend.
8. Write the principle of mutual inductance?
9. List the factors on which mutual-inductance of a coil depends.

Two marks questions (Understanding):

1. Distinguish between active and passive components.
2. How to troubleshoot a capacitor?
3. Distinguish between self-inductance and mutual-inductance.
4. Explain the terms in the expression of mutual inductance of a coil.
5. How is energy stored in an inductor? Write its expression.
6. How is the impedance behavior of inductor towards AC and DC?
7. With an appropriate diagram, write the expression for inductors connected in series.
8. With an appropriate diagram, write the expression for inductors connected in parallel.
9. Write any two applications of transformer.
10. How step up transformer differs from step down transformer.
11. Why centre tapping is necessary?
12. Give two examples for pressure transducer.
13. Distinguish between speaker and microphone.

Two marks questions (Application):

1. The resistance of a coil made of copper wire is $100\ \Omega$ at 0°C . Calculate its resistance at 30°C .
Given $\alpha = 0.004/^\circ\text{C}$. Ans: $R_t = 112\ \Omega$
2. Calculate the resistor value that has Brown–Black–Yellow–Gold colour bands. Ans: $100\ \text{k}\Omega \pm 5\%$
3. Two capacitor plates each of effective area $6 \times 10^{-4}\ \text{m}^2$ are separated by 1.3×10^{-3} meter. Find its capacitance. The space between the plates is filled with air. Ans: $C = 4.086\ \text{pF}$
4. How much energy is stored in a $20\ \mu\text{F}$ capacitor with a voltage rating of 15 volts? Ans: $2250\ \mu\text{J}$
5. Determine the charge on $30\ \mu\text{F}$ capacitor charged to 20 V. Ans: $600\ \mu\text{C}$
6. Write the applications of transformer.

Three marks questions (Knowledge):

1. Write a note on SMD resistor.
2. Write a note on presets.
3. Write a note on power rating of a resistor.
4. Write a note on trimmers.
5. Write the constructional features of ganged capacitor.
6. Write the constructional features of SMD capacitor.
7. Write a note on iron core inductor.
8. Write a note on ferrite core inductor.
9. Write a note on centre tapping in transformer.

Three marks questions (Understanding):

1. Explain the construction of carbon composition resistor.
2. Derive an expression for the equivalent capacitance of two capacitors connected in parallel.
3. Describe the construction of a ceramic capacitor.
4. Explain the role of dielectric in capacitor construction.
5. Explain the phenomenon of self-induction.
6. Explain the phenomenon of mutual induction.
7. Explain the construction of air core inductor.
8. Define efficiency of a transformer. Write its expression.
9. Explain the principle of transformer.

Three marks questions (Application):

1. The resistance of a wire of length 1 m and of diameter 0.12 mm is $40\ \Omega$. What is its specific resistance? Ans: $0.45216 \times 10^{-6}\ \Omega\text{m}$
2. Two capacitors of capacitance $20\ \mu\text{F}$ and $30\ \mu\text{F}$ are connected in series across 200 V dc supply. Determine a) effective capacitance. b) total charge on combination. Ans: $12\ \mu\text{F}$, $2400\ \mu\text{C}$
3. Two capacitors of capacitance $60\ \mu\text{F}$ each are connected in parallel. The combination is further connected in series with capacitor of $30\ \mu\text{F}$. Determine effective capacitance. Ans: $24\ \mu\text{F}$

- A two cm long air core coil with cross sectional area of 3 cm^2 has 10 turns. Determine the inductance of the coil
Ans: $L = 1.88 \mu\text{H}$
- A five mH inductor is subjected to an electric current that changes at a rate of 5 A per second. How much voltage will be dropped by the inductor?
Ans: 250 mV
- Calculate the energy stored in the magnetic field of 100 mH inductor with a current of 80 mA.
Ans: 320 μJ

Five marks questions (Applications):

- Complete the following table for the carbon resistor R.

Sl.no.	I band	II band	III band	IV band	Value of R
1	Orange	Red	Red	Gold	
2					$100 \text{ k} \pm 10\%$
3	Brown	Black	orange	Silver	
4					$47 \text{ k} \pm 20\%$

Ans: (1) $3.2 \text{ k}\Omega \pm 5\%$
(2) Brown, Black, Yellow and Silver (3) $10\text{k}\Omega \pm 10\%$ (4) Yellow, Violet, Orange and No colour.

- Two capacitors of $60 \mu\text{F}$ each are connected in parallel. The combination is further connected in series with two capacitors of $30 \mu\text{F}$ and $75 \mu\text{F}$. Calculate the total capacitance of the Circuit.
Ans = $18.18 \mu\text{F}$
- Two capacitors of capacitance $10 \mu\text{F}$ and $30 \mu\text{F}$ are connected in series across 100 V dc supply. Determine a) effective capacitance b) the total charge on combination c) potential difference across each capacitor.
Ans: (a) $7.5 \mu\text{F}$ (b) $750 \mu\text{C}$ (c) 75 V, 25 V
- A step down transformer having a power output of 10 kW and efficiency 90% reduces the voltage from 11 kV to 220 V. Calculate (i) the number of turns in the primary if the secondary has 100 turns and (ii) the current in the primary.
Ans: 5000 and 0.909 A
- Calculate the voltage output by the secondary winding of a transformer if the primary voltage is 220V, the secondary winding has 4000 turns; the primary winding has 400 turns. What is the turn ratio?
Ans: 2200 V, 1:10
- Calculate the load current and load voltage in this transformer circuit:

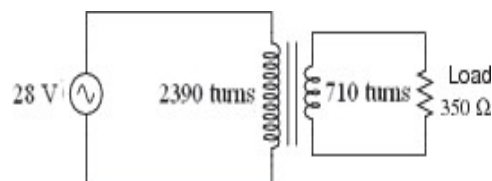

Ans: $I_{\text{load}} = 23.77 \text{ mA}$, $V_{\text{load}} = 8.318 \text{ V}$

Five marks questions (Knowledge):

1. Write the constructional features of electrolytic capacitor and mention its applications.
2. Describe the construction and working of a transformer.
3. Describe the construction and working of a moving coil loudspeaker.

Five marks questions (Understanding):

1. Explain the important specifications of resistor.
2. Explain the principle of capacitor.
3. Explain the construction of a polystyrene capacitor.
4. Derive an expression for the equivalent capacitance of three capacitors connected in series.
5. Derive an expression for the equivalent capacitance of three capacitors connected in parallel.
6. Explain the phenomenon of mutual-induction.
7. Explain the construction and working of microphone.

Chapter 5

Application of DC and AC to passive components

Choose the correct answer:

1.	The time taken by the capacitor to charge from 0 to 63.2% of supply voltage in an RC circuit connected to DC supply is called (a) RC time duration (b) RC time constant (c) RC time variation (d) RC time slot (b) RC time constant
2.	In an RC circuit connected to DC source, voltage across the capacitor increases (a) Linearly (b) Constantly (c) Exponentially (d) Logarithmically (c) Exponentially
3.	The relationship between resistance R, capacitance C and the charging time constant τ is given by (a) $\tau = RC$ (b) $\tau = \frac{R}{C}$ (c) $\tau = \frac{C}{R}$ (d) $\tau = \sqrt{RC}$ (a) $\tau = RC$
4.	An expression for the instantaneous charging voltage across capacitor in an RC circuit is (a) $v_C = \sqrt{E}[1 - e^{(-\frac{t}{RC})}]$ (b) $v_C = E[1 - e^{(-\frac{t}{RC})}]$ (c) $v_C = E^2[1 - e^{(-\frac{t}{RC})}]$ (d) $v_C = 2E[1 - e^{(-\frac{t}{RC})}]$ (b) $v_C = E[1 - e^{(-\frac{t}{RC})}]$
5.	The time constant of a RC circuit during charging and discharging (a) remains the same (b) is different (c) depends on the supply voltage (d) depends on the circuit current (a) remains the same
6.	An expression for instantaneous growth of current in RL circuit is (a) $I = 2I_m[1 - e^{(-\frac{Rt}{L})}]$ (b) $I = I_m[1 - e^{(-\frac{Rt}{L})}]$ (c) $I = I_m^2[1 - e^{(-\frac{Rt}{L})}]$ (d) $I = I_m[\sqrt{1 - e^{(-\frac{Rt}{L})}}]$ (b) $I = I_m[1 - e^{(-\frac{Rt}{L})}]$
7.	The unit of capacitive reactance is (a) Joule (b) Hertz (c) ohm (d) watt (c) ohm
8.	In an AC circuit containing pure inductor current lags behind the voltage by (a) 0° (b) 90° (c) 180° (d) 270° (b) 90°

9.	The expression for the inductive reactance is (a) $X_L = 2\pi fL$ (b) $X_L = 2\pi \sqrt{fL}$ (c) $X_L = \sqrt{2\pi fL}$ (d) $X_L = \frac{1}{2\pi fL}$ (a) $X_L = 2\pi fL$
10.	In an AC circuit containing pure capacitor current leads the voltage by (a) 0° (b) 90° (c) 180° (d) 270° (b) 90°
11.	In series RLC circuit, the current will be maximum when (a) $X_L = X_C$ (b) $X_L < X_C$ (c) $X_L > X_C$ (d) $X_L = \sqrt{X_C}$ (a) $X_L = X_C$
12.	In series RLC circuit, the impedance Z at resonance is equal to (a) R (b) X_L (c) X_C (d) $X_L + X_C$ (a) R
13.	The expression for the capacitive reactance is (a) $X_C = \frac{1}{2\pi\sqrt{fC}}$ (b) $X_C = \frac{1}{2\pi fC}$ (c) $X_C = \frac{1}{\sqrt{2\pi fC}}$ (d) $X_C = \frac{1}{4\pi^2 \sqrt{fC}}$ (b) $X_C = \frac{1}{2\pi fC}$
14.	Expression of the average power is (a) $P_{avg} = V_{rms} I_{rms} \cos\phi$ (b) $P_{avg} = \sqrt{V_{rms} I_{rms} \cos\phi}$ (c) $P_{avg} = \frac{1}{\sqrt{V_{rms} I_{rms} \cos\phi}}$ (d) $P_{avg} = \frac{1}{V_{rms} I_{rms} \cos\phi}$ (a) $P_{avg} = V_{rms} I_{rms} \cos\phi$
15.	The maximum value of power factor in an ac circuit can be (a) 0 (b) 1 (c) ∞ (d) none of these (b) 1
16.	The unit of impedance is (a) Mho (b) ohm (c) volt (d) watt (b) ohm
17.	The expression for the impedance of a series RLC circuit is (a) $Z = \sqrt{R^2 + (X_L - X_C)^2}$ (b) $Z = \sqrt{R^2 + (X_L + X_C)^2}$ (c) $Z = \sqrt{R^2 - (X_L \div X_C)^2}$ (d) $Z = \sqrt{R^2(X_L \div X_C)^2}$ (a) $Z = \sqrt{R^2 + (X_L - X_C)^2}$
18.	The following does not influence the resonant frequency of a series RLC circuit (a) X_L (b) R (c) X_C (d) Z (b) R

19.	<p>The expression for the resonance frequency of a series resonance circuit is</p> <p>(a) $f_r = \frac{1}{2\pi\sqrt{LC}}$ (b) $f_r = \frac{1}{2\pi\frac{L}{C}}$ (c) $f_r = \frac{1}{\sqrt{2\pi^2L^2C^2}}$ (d) $f_r = \frac{1}{4\pi^2\sqrt{LC}}$</p> <p>(a) $f_r = \frac{1}{2\pi\sqrt{LC}}$</p>
20.	<p>Write the relation between quality factor, bandwidth and resonance frequency.</p> <p>(a) $Q = \frac{f_r}{BW}$ (b) $Q = \frac{\sqrt{f_r}}{BW}$ (c) $Q = \frac{f_r}{\sqrt{BW}}$ (d) $Q = \sqrt{\frac{f_r}{BW}}$</p> <p>(a) $Q = \frac{f_r}{BW}$</p>
21.	<p>The power consumed by a pure capacitive circuit is</p> <p>(a) zero (b) infinity (c) unity (d) none of these</p> <p>(a) zero</p>
22.	<p>A filter circuit that passes signals below its cutoff frequency while attenuating all signals above it is</p> <p>(a) low pass filter (b) high pass filter (c) band pass filter (d) none of these</p> <p>(a) low pass filter</p>
23.	<p>A filter circuit which passes signals above its cutoff frequency and attenuates all signals below it is</p> <p>(a) low pass filter (b) high pass filter (c) band pass filter (d) none of these</p> <p>(b) high pass filter</p>
24.	<p>In a RC low pass filter the phase angle of input and output signal is</p> <p>(a) $\phi = \tan^{-1}(1/\omega RC)$ (b) $\phi = \cos^{-1}(1/\omega RC)$ (c) $\phi = \sin^{-1}(1/\omega RC)$ (d) $\phi = -\tan^{-1}(\omega RC)$</p> <p>(d) $\phi = -\tan^{-1}(\omega RC)$</p>
25.	<p>Expression for cut-off frequency of RC low pass filter is</p> <p>(a) $f_c = \frac{1}{2\pi RC}$ (b) $f_c = \frac{1}{2\pi\sqrt{RC}}$ (c) $f_c = \frac{1}{\sqrt{2\pi} RC}$ (d) $f_c = \frac{1}{\sqrt{2\pi RC}}$</p> <p>(a) $f_c = \frac{1}{2\pi RC}$</p>
26.	<p>Expression for cut-off frequency of RC high pass filter is</p> <p>(a) $f_c = \frac{1}{2\pi RC}$ (b) $f_c = \frac{1}{2\pi\sqrt{RC}}$ (c) $f_c = \frac{1}{\sqrt{2\pi} RC}$ (d) $f_c = \frac{1}{\sqrt{2\pi RC}}$</p> <p>(a) $f_c = \frac{1}{2\pi RC}$</p>

Fill in the blanks:

1.	A period of time, where the voltage or current changes from one steady state to another steady state is called as _____ transient period
2.	An expression for the instantaneous discharging voltage across capacitor is _____ $v_C = V[e^{(-\frac{t}{RC})}]$
3.	An expression for instantaneous decay of current in RL circuit is _____ $i = I_m[e^{(-\frac{Rt}{L})}]$
4.	The time taken by the current to rise from 0 to 0.632 (or 63.2%) of its final steady value is termed as _____ of RL circuit. time constant
5.	The difference between the phases of the two alternating quantities is called the _____ phase difference
6.	Two ac quantities are said to be out of phase when they are in different _____ directions
7.	The phase difference between voltage and current in a purely resistive circuit is _____ 0°
8.	Inductor acts as a _____ for DC. short
9.	The opposition offered by a capacitor to the flow of AC through it is called _____ capacitive reactance
10.	The unit of capacitive reactance is _____ Ω (ohm)
11.	Capacitor acts as a _____ for DC. open
12.	The ratio of the active power to apparent power is called as _____ power factor (or) cosφ
13.	The power factor of AC circuit lies in between _____ 0 to 1
14.	The unit of impedance is _____ Ω (ohm)
15.	The condition for resonance of a series RLC circuit is _____ $X_L = X_C$
16.	The power consumed by a pure inductive circuit is _____ zero
17.	The power consumed by a pure capacitive circuit is _____ zero
18.	A circuit which allows only a certain range of frequencies to pass through it, and attenuates the other frequencies is called _____ filter
19.	The frequency at which the voltage gain reduces to 0.707 of the maximum gain is called as _____ cut – off frequency
20.	At cut off frequencies the output power becomes half of the maximum output _____ power

One mark questions (Knowledge):

1. What is a transient period?
2. Define time constant of RC circuit.
3. Define time constant of RL circuit.
4. What is a phase?
5. What is phase difference?
6. Write the unit of capacitive reactance.
7. What is inductive reactance?
8. Define average power.
9. Define reactive power.
10. Define apparent power.
11. Define power factor.
12. Define impedance.
13. What is the unit of impedance?
14. What is bandwidth?
15. What is low pass filter?
16. What is high pass filter?
17. Define quality factor.

One mark questions (Understanding):

1. What do you mean by transient response?
2. Write an expression for the voltage across capacitor during charging.
3. Write an expression for the voltage across capacitor during discharging.
4. Write an expression for the instantaneous current in RL circuit, during the growth of current.
5. Write an expression for the instantaneous current in RL circuit, during the decay of current.
6. Two AC quantities are in phase. What is the value of phase angle between them?
7. What do you understand by phase lead?
8. What do you understand by phase lag?
9. Do you think resistance offered by the resistor is same for AC and DC?
10. Do you think resistance offered by the capacitor is same for AC and DC?
11. Do you think resistance offered by the inductor is same for AC and DC?
12. What do you mean by capacitive reactance?
13. Give an expression for the inductive reactance.
14. What do you mean by half power frequency?
15. How do you relate quality factor, bandwidth and resonance frequency?
16. Give an expression for the resonance frequency of a series resonance circuit.
17. Give the condition for the resonance of series RLC circuit.
18. Which expression is used to calculate the impedance of series RLC circuit?
19. Write the expression for phase difference between current and voltage in series RLC circuit.
20. What is a filter?

One mark questions (Application):

1. Draw the phasor diagram of voltage and current in a purely resistive circuit.
2. Draw the phasor diagram of voltage and current in a purely capacitive circuit.
3. Draw the phasor diagram of voltage and current in a purely inductive circuit.
4. Draw the waveform of two in phase AC quantities.
5. Draw the waveform of two AC quantities that are 180° out of phase.
6. Sketch the phasor diagram of two AC quantities that are 90° out of phase.
7. Give the expression for phase angle between current and voltage in series RLC circuit?
8. Sketch the frequency response curve of high-pass filter.

Two marks questions (Knowledge):

1. Write expressions for instantaneous voltage and currents for an AC circuit containing pure capacitor.
2. Write expressions for instantaneous voltage and currents for an AC circuit containing pure inductor.
3. What is capacitive reactance and give the expression for the capacitive reactance.
4. Write a brief note on impedance of a circuit.

Two marks questions (Understanding):

1. What happen to the power for purely reactive circuit with voltage and current at 90° out of phase?
2. Describe the phenomenon of resonance in a series resonance circuit.
3. Define inductive reactance and write the expression for the inductive reactance.
4. Define capacitive reactance and write the expression for the capacitive reactance.
5. Derive an expression for resonant frequency of series resonance circuit.

Two marks questions (Applications):

1. Draw the graph showing voltage across capacitor during charging in RC circuit.
2. Draw the graph showing voltage across capacitor during discharging in RC circuit.
3. Draw the graph showing growth of current in RL circuit.
4. Determine the time constant of an RC circuit when $R = 22 \text{ k}\Omega$ and $C = 0.05 \text{ }\mu\text{F}$.
Ans: $\tau = 1.1 \text{ mS}$
5. Determine the time constant of an RL circuit when $R = 100 \text{ }\Omega$ and $L = 100\text{mH}$. Ans: $\tau = 1 \text{ mS}$
6. The time constant of an RL circuit is 4 mS , if $L = 100 \text{ mH}$, calculate the value of resistance.
Ans: $R = 25 \text{ }\Omega$
7. The time constant of an RL circuit is $1 \text{ }\mu\text{S}$, if $R = 20 \text{ k}\Omega$, calculate the value of inductance.
Ans: $L = 20 \text{ mH}$
8. Draw the circuit diagram of low pass filter and high pass filter.

Three marks questions (Knowledge):

1. Write a note on AC applied to pure resistive circuit.
2. Write a note on AC applied to pure capacitive circuit.
3. Write a note on AC applied to pure inductive circuit.
4. What are the advantages of phasor diagram.

Three marks questions (Understanding):

1. Discuss the charging of capacitor in RC circuit.
2. Discuss the discharging of capacitor in RC circuit.
3. Discuss the growth of current in RL circuit.
4. Discuss the decay of current in RL circuit.

Three marks questions (Application):

1. Determine the current through an inductor during the growth at $t = 1$ S in a DC circuit containing $R = 1 \Omega$ and $L = 1$ H connected to DC supply of 20 V. Ans: 12.64 A
2. Determine the voltage across the capacitor and maximum current during charging at $t = 1$ S in a DC circuit containing $R = 1$ M Ω and $C = 1$ μ F connected to DC supply of 10 V. Ans: $V_c = 6.32$ V, $I_o = 10$ μ A
3. What is the reactance of a 3 mH inductor connected to an AC of 200 V, 120 Hz? Ans: 2.261 Ω
4. A 2.5 mH inductor is placed in a circuit, where the frequency is 100 kHz and voltage is 50 V. Calculate Inductive reactance and peak current? Ans: $X_L = 1570 \Omega$, $I_m = 31.84$ mA
5. What is the capacitive reactance of a 0.01 μ F capacitor at 400 Hz? Ans: $X_C = 39.8$ k Ω
6. An inductor of 20 mH is connected in series with a resistor of 50 Ω . The combination is connected to 220 V, 50 Hz source. Find the current in the circuit. Ans: $I = 4.36$ A
7. A series RLC circuit has $R = 20 \Omega$, $C = 0.01$ μ F, $L = 10$ mH. Calculate resonant frequency. Ans: $f_c = 15.9$ k Ω

Five marks questions (Application):

1. A coil of 100 mH having a resistance of 100 Ω is connected across a source of 200 V, 50 Hz. Find the phase angle and current in the circuit. Ans: $\phi = 17.43^\circ$, $I = 1.9$ A
2. A 10 Ω resistance in series with $X_L = 50 \Omega$ and $X_C = 25 \Omega$. The applied voltage is $V = 50$ mV with 50 Hz. Calculate Z, I and phase angle. Ans: $Z = 26.92 \Omega$, $I = 1.85$ mA, $\phi = 68.19^\circ$.

Five marks questions (Knowledge):

1. Discuss charging and discharging of capacitor in a RC circuit.
2. Discuss the growth and decay of current in a RL circuit.

Five marks questions (Understanding):

1. Derive an expression for impedance in a series RLC circuit.
2. Explain low pass filter with its frequency response
3. Explain high pass filter with its frequency response

Chapter 6

Semiconductors, diodes and applications of diodes

Choose the correct answer:

1.	The energy band formed by valence electrons in a solid is called as (a) conduction band (b) forbidden band (c) valence band (d) covalent band (c) valence band
2.	The energy band formed by free electrons (conduction band electrons) in a solid is known as (a) conduction band (b) forbidden band (c) valence band (d) covalent band (a) conduction band
3.	The energy difference between the valence band and conduction band is (a) conduction gap (b) forbidden energy gap (c) valence gap (d) covalent gap (b) forbidden energy gap
4.	Free electrons exist in (a) forbidden energy band (b) valence band (c) conduction band (d) none of these (c) conduction band
5.	In insulators the forbidden gap is (a) 0 eV (b) 1 eV (c) 5 eV (d) 100 eV (c) 5 eV
6.	In conductors the forbidden gap is (a) wide (b) narrow (c) absent (d) none of these (c) absent
7.	In semiconductors the forbidden gap is (a) 0 eV (b) 1 eV (c) 5 eV (d) 100 eV (b) 1 eV
8.	The majority charge carriers in P-type semiconductor are (a) holes (b) electrons (c) protons (d) neutrons (a) holes
9.	The minority charge carriers in P-type semiconductor are (a) holes (b) electrons (c) protons (d) neutrons (b) electrons
10.	The value of resistance of p-n junction, when it is forward biased is (a) very high (b) very low (c) infinite (d) none of these (b) very low
11.	Barrier voltage of silicon diode is (a) 0.7 V (b) 0.3 V (c) 0.7 eV (d) 0.3 eV (a) 0.7 V
12.	Barrier potential of germanium diode is (a) 0.7 V (b) 0.3 V (c) 0.7 eV (d) 0.3 eV (b) 0.3 V
13.	Vacancy site of electrons is called as a (a) hole (b) electron (c) potential barrier (d) ions

	(a) hole
14.	An intrinsic semiconductor behaves like a perfect insulator at (a) absolute zero temperature (b) room temperature (c) above room temperature (d) none of these (a) absolute zero temperature
15.	An intrinsic semiconductor becomes N-type when doped with (a) trivalent atoms (b) pentavalent atoms (c) tetravalent atoms (d) none of these (b) pentavalent atoms
16.	An intrinsic semiconductor becomes P-type when doped with (a) trivalent atoms (b) pentavalent atoms (c) tetravalent atoms (d) none of these (a) trivalent atoms
17.	Diode is a (a) unidirectional device (b) bidirectional device (c) voltage controlled device (d) current controlled device (a) unidirectional device
18.	The current that flows through the reverse biased p-n junction diode due to flow minority carriers is called (a) reverse saturation current (b) forward leakage current (c) reverse current (d) dark current (a) reverse saturation current
19.	The minimum forward-biased voltage that is required for the conduction of p-n junction diode is called (a) knee voltage (b) break down voltage (c) leakage voltage (d) peak inverse voltage (a) knee voltage
20.	A diode which acts as closed switch when forward biased and acts as an open switch when reverse biased is called as an (a) ideal diode (b) dead diode (c) practical diode (d) none of these (a) ideal diode
21.	The circuits used for signal shaping are known as (a) wave shaping circuits (b) wave selection circuit (c) wave propagation circuits (d) none of these (a) wave shaping circuits
22.	A wave shaping circuit used to remove a portion of the input signal without distorting the remaining part of the waveform is called as (a) clamper (b) clipper (c) damper (d) none of these (b) clipper
23.	An electronic circuit which converts AC signal to pulsating DC signal is called (a) rectifier (b) amplifier (c) filters (d) purifier (a) rectifier
24.	Which of these components is used in rectifier circuit?

	(a) Transformer (d) all of these	(b) Load resistor	(c) Diode	(d) all of these
25.	The value of ripple factor in half-wave rectifier is			
	(a) 0.48 (d) 1.21	(b) 2.12	(c) 4.80	(d) 1.21
26.	The value of ripple factor in full-wave rectifier is			
	(a) 0.48 (a) 0.48	(b) 2.12	(c) 4.80	(d) 1.21
27.	Maximum efficiency of half-wave rectifier is			
	(a) 40.6 % (a) 40.6 %	(b) 81.2 %	(c) 100 %	(d) 10 %
28.	Maximum efficiency of full wave rectifier is			
	(a) 40.6 % (b) 81.2 %	(b) 81.2 %	(c) 100 %	(d) 10 %
29.	The number of diodes used in half-wave rectifier is _____			
	(a) 1 (a) 1	(b) 2	(c) 4	(d) 0
30.	The number of diodes used in full-wave center-tapped rectifier is _____			
	(a) 1 (b) 2	(b) 2	(c) 4	(d) 0
31.	The number of diodes used in full-wave bridge rectifier is _____			
	(a) 1 (c) 4	(b) 2	(c) 4	(d) 0
32.	PIV of HWR is			
	(a) V_m (a) V_m	(b) $2V_m$	(c) $V_m/2$	(d) $4V_m$
33.	DC voltage of FWR is			
	(a) πV_m (c) $2V_m/\pi$	(b) V_m/π	(c) $2V_m/\pi$	(d) $4V_m/\pi$
34.	RMS value of voltage in HWR is			
	(a) V_m (c) $V_m/2$	(b) $2V_m$	(c) $V_m/2$	(d) $4V_m$
35.	A heavily doped semiconductor diode designed to operate in the breakdown region is			
	(a) photo diode (c) Zener diode	(b) varactor diode	(c) Zener diode	(d) tunnel diode
36.	A Zener diode is usually operated in			
	(a) zero bias (c) reverse bias	(b) forward bias	(c) reverse bias	(d) no bias
37.	A Zener diode can be used as			
	(a) current regulator (b) voltage regulator	(b) voltage regulator	(c) frequency regulator	(d) none of these
38.	A series resistance is connected in the Zener diode circuit			
	(a) for line regulation (c) both (a) and (b) are true (c) both (a) and (b) are true	(b) to protect the Zener diode	(c) both (a) and (b) are false	

39.	In a Zener voltage regulator, the variation in load current produces variation in (a) Zener voltage (b) Zener current (c) change in source voltage (d) none of these (b) Zener current
40.	A circuit which maintains output voltage constant irrespective of any change in supply voltage and load is known as (a) voltage regulator (b) current regulator (c) frequency regulator (d) optical regulator (a) voltage regulator
41.	The LM78XX series regulator is three terminal (a) positive fixed voltage regulators (b) negative fixed voltage regulators (c) positive variable voltage regulator (d) negative variable voltage regulator (a) positive fixed voltage regulators
42.	The LM79XX series regulator is three terminal (a) positive fixed voltage regulators (b) negative fixed voltage regulators (c) positive variable voltage regulator (d) negative variable voltage regulator (b) negative fixed voltage regulators
43.	The component used to construct adjustable voltage regulator is (a) LM 317 (b) LM555 (c) μ A741 (d) IC7400 (a) LM 317

Fill in the blanks:

1.	Conductivity of _____ lies between conductors and insulators. semiconductors
2.	The amount of energy possessed by an electron in an isolated atom is called _____. energy level
3.	The range of closely spaced energies possessed by electrons of particular orbit in a solid is called _____. energy band
4.	Protons have _____ charges. positive
5.	Semiconductor in its purest form is called _____ semiconductor. intrinsic
6.	Sharing of valence electrons between two atoms of same material or different material is known as _____ bond. covalent
7.	The process of adding impurity atoms to a pure semiconductor is called _____. doping
8.	The impurity atoms added to intrinsic semiconductor are called _____. dopants
9.	A doped semiconductor is called _____ semiconductor. extrinsic

10.	The majority charge carriers in N-type semiconductor are _____ electrons
11.	The minority charge carriers in N-type semiconductor are _____ holes
12.	_____ is formed by doping donor impurity one side and acceptor impurity into the other side of the semiconductor crystal. p-n junction
13.	The process of connecting DC voltage source to the terminals of a diode is called _____ biasing
14.	In _____ P-region of the diode is connected to positive terminal and the N-region to negative terminal of the battery. forward bias
15.	Reverse biased p-n junction has _____ resistance. very high
16.	The region near the junction where no free electrons or holes are present is called _____ depletion region or space charge region
17.	The potential difference established across a p-n junction is referred as _____ potential barrier
18.	Junction break down in a diode occurs with very high _____ reverse bias
19.	The reverse saturation current is also called as _____ reverse leakage current
20.	The reverse saturation current in germanium diode will be doubled after every _____ rise in temperature. $10^0 C$
21.	The forward voltage at which the current through the diode starts increasing rapidly is known as _____ knee voltage
22.	The reverse voltage at which p-n junction breaks is known as _____ break down voltage
23.	The maximum value of reverse voltage that a p-n junction can withstand without damaging to itself is called its _____ peak inverse voltage
24.	A circuit used to place either the positive peak or negative peak of a signal at a desired dc level is known as _____ clamping circuit or clamper
25.	An electronic circuit which converts AC signal to pulsating DC signal is called _____ rectifier
26.	In a rectifier output, the ratio of r.m.s value of a.c component to the d.c component is known as _____ ripple factor
27.	The circuit which eliminates ripples in rectified output is called _____ filter

28.	A heavily doped semiconductor diode designed to operate in the breakdown region is _____ Zener diode
29.	_____ keeps load voltage constant even input voltage and load resistance changes. Voltage regulator
30.	The active component used to construct +12V fixed voltage regulator is _____ IC-7812
31.	The active component used to construct -12V fixed voltage regulator is _____ IC-7912
32.	LED emits light when _____ recombine with holes. electrons
33.	LED stands for _____ Light Emitting Diode.
34.	LED emits light only when it is _____ forward biased
35.	A device used for displaying a digit or a letter is a _____ seven segment display

One mark questions (knowledge):

1. What are conductors?
2. What are semiconductors?
3. Define valence band.
4. Define conduction band.
5. Name the majority charge carriers in n-type semiconductor.
6. Name the majority charge carriers in p-type semiconductor.
7. What is forbidden energy gap?
8. What is doping?
9. Name any one acceptor impurity atom.
10. Name any one donor impurity atom.
11. What is the value of potential barrier of a silicon diode?
12. Write the symbol of a p-n junction diode.
13. What is the static resistance of a diode?
14. Define dynamic resistance of a junction diode.
15. What is reverse saturation current?
16. Mention the Shockley's equation for diode.
17. What is an ideal diode?
18. What is clipping circuit?
19. What is a clamper?
20. What is rectification?
21. What is a rectifier?
22. What is the function of a filter in rectifier circuit?
23. What is a Zener diode?
24. Write the schematic symbol of a Zener diode.
25. Define Zener breakdown voltage.

26. Mention the main application of Zener diode.
27. What is line regulation?
28. What is load regulation?
29. What is LED?
30. Mention any one application of a seven segment display.
31. Name the IC regulator used to construct +12 V fixed voltage regulator.
32. Name the IC regulator used to construct adjustable positive voltage regulator.

One mark questions (Understanding):

1. How p-n junction is formed?
2. What is meant by depletion region?
3. What do you mean by potential barrier?
4. What is meant by biasing a p-n junction?
5. What is meant by forward biasing of diode?
6. What do you mean by reverse bias of diode?
7. What is the effect of forward bias on the width of a p-n junction?
8. What is the effect of reverse bias on the width of a p-n junction?
9. Is reverse saturation current dependent on temperature?
10. What do you mean by junction breakdown?
11. Give the expression for transition capacitance.
12. Write the equivalent circuit of a reverse biased ideal diode.
13. Write the equivalent circuit for second approximation of a diode.
14. Write the equivalent circuit for third approximation of a diode.
15. What is the power rating of a diode?
16. What is the importance of peak inverse voltage?
17. What is the value of ripple factor in half wave rectifier?
18. In what respect Zener diode is different from an ordinary diode.
19. Name any one active component used for voltage regulation.
20. Under which bias LED is operated?
21. During which process light is emitted from LED?

One mark questions (Application):

1. Draw the equivalent circuit of a forward biased ideal diode.
2. In the figure shown, is the diode D forward or reverse biased?

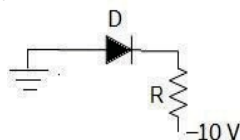

3. In which type of bias, does the p-n junction diode offer high resistance?
4. Sketch the shape of the output voltage waveform for the circuit shown below assuming the diode to be ideal.

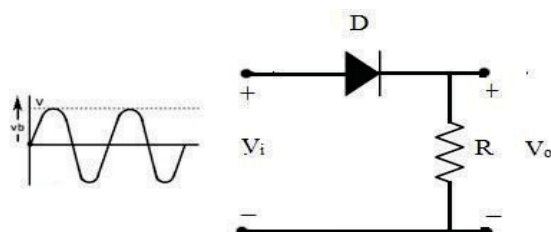

5. Sketch the shape of the output voltage waveform for this circuit shown below assuming the diode to be ideal.

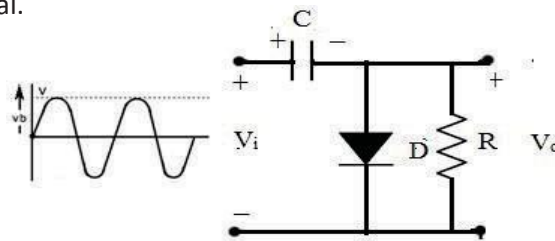

6. Determine average DC voltage of HWR. Given $V_m = 9V$.
 7. Draw the equivalent circuit of a Zener diode.
 8. Draw the schematic symbol of LED.

Ans: $V_{av} = 2.86 V$

Two marks questions (Knowledge):

1. Classify extrinsic semiconductor.
2. Mention majority and minority charge carriers in n-type semiconductor.
3. Draw the crystalline structure of a p-type semiconductor.
4. Mention the typical values of knee voltage for Ge and Si diodes.
5. Define ideal diode. Draw its V-I characteristics.
6. Mention any two applications of a diode.
7. Mention wave shaping circuits.
8. What is clipping circuit? Mention any one application of clipping circuit.
9. What is clamping circuit? Mention any one application of clamping circuit.
10. Write the circuit of series positive clipper and show the input and output waveforms.
11. Write the circuit of series negative clipper and show the input and output waveforms.
12. Write the circuit of positive clamper and show the input and output waveforms.
13. Write the circuit of negative clamper and show the input and output waveforms.
14. Define ripple factor and give its significance.
15. Write the circuit diagram of a full wave rectifier along with the input and output wave forms.
16. What are the values of rectification efficiency of a full wave rectifier and half wave rectifier?
17. What is Zener break down?
18. What is voltage regulation? Mention the types of voltage regulation.
19. Write any two application of LED.

Two marks questions (Understanding):

1. Explain the phenomenon of diode reverse breakdown.
2. What do you mean by the transition capacitance of a diode?
3. A p-n junction diode is a non linear element. Explain.
4. Distinguish between Ge and Si diode.
5. Explain the second approximation of a semiconductor diode.
6. Explain the third approximation of a semiconductor diode.
7. Distinguish between positive and negative clipper?
8. What is the difference between positive and negative clamper?
9. How many diodes are used in a (i) Centre tapped full wave rectifier and (ii) Bridge rectifier?

- Distinguish between full wave rectifier and half wave rectifier.
- Distinguish between series inductor filter and shunt capacitor filter.
- Explain the need of a voltage regulator circuit in a power supply.

Two marks questions (Application):

- Draw the lattice structure of silicon.
- Draw the circuit diagram of a forward biased p–n junction diode.
- Draw the circuit diagram of a reverse biased p–n junction diode.
- A silicon diode has a bulk resistance of 1.5Ω and a forward current of 10 mA . What is the forward voltage drop across the diode? Ans: 0.715 V
- Draw the VI Characteristics of Zener diode.
- Draw the circuit diagram of $+12 \text{ V}$ voltage regulator.
- Draw the circuit diagram of an adjustable voltage regulator.
- Draw the diagram of seven segment LED display.

Three marks question (Knowledge):

- Classify solids based on energy band diagram.
- Write the properties of semiconductor.
- Briefly explain n–type semiconductors.
- Briefly explain p–type semiconductors.
- Write a note on diode junction capacitance.
- Write a note on diode specifications.
- Write a note on diode approximations.
- Write a note on fixed positive regulator.

Three marks questions (Understanding):

- How is the depletion region formed in a p–n junction?
- Explain the working of a p–n junction when it is forward biased.
- Explain the action of series positive clipper.
- Explain the action of series negative clipper.
- Explain the working of positive clamper.
- Explain the working of negative clamper.
- Explain the working of a p–n junction when it is reverse biased.
- Explain the working of LED.

Three marks questions (Application):

- A silicon diode dissipates 2.5 W for a forward current of 1.5 A . Determine the forward voltage drop across the diode and its bulk resistance. Ans: $V_F = 1.66 \text{ V}$, $R_B = 0.64 \Omega$
- Calculate the load voltage and load current for the circuit shown.

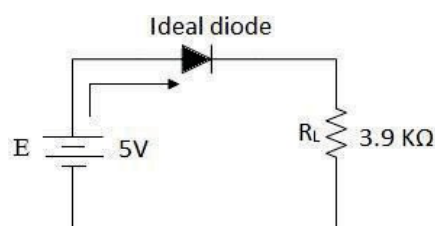

Ans: $V_L = 5 \text{ V}$, $I_L = 1.28 \text{ mA}$

3. A silicon diode is used in the circuit shown in figure. Determine V_D , V_R and I_D .

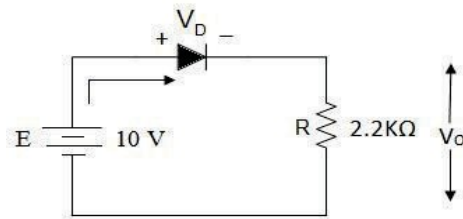

Ans: $V_D = 0.7 \text{ V}$, $V_R = 9.3 \text{ V}$ and $I_R = 4.22 \text{ mA}$

4. For the series diode configuration shown in figure, determine the current I_D and V_R .

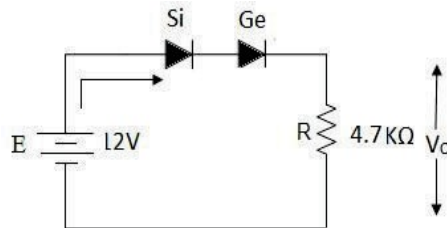

Ans: $V_R = 11 \text{ V}$, $I_R = 2.34 \text{ mA}$

5. Find the value of an applied voltage for Si diode having bulk resistance 25Ω and a forward current of 2 mA .
 6. A germanium diode is used in the circuit shown in figure. Determine V_D , V_R and I_D .

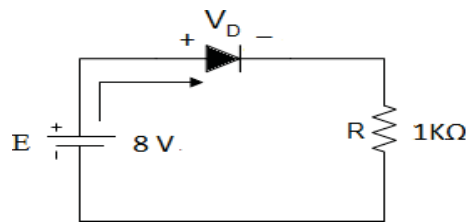

Ans: $V_D = 0.3 \text{ V}$, $V_R = 7.7 \text{ V}$, $I_D = 7.7 \text{ mA}$

7. Determine the current through $1 \text{ k}\Omega$ resistor.

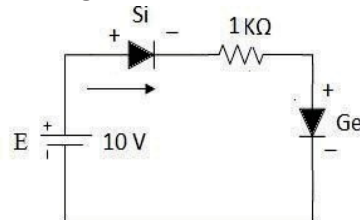

Ans: 9 mA

8. In a power supply the DC output voltage drops from 65 V with no load to 60 V at full load. Calculate the percentage voltage regulation
 9. Ideal diodes are used in constructing a full wave bridge rectifier circuit. An ac 200 V , 50 Hz applied across a transformer. If $N_p = 500$ turns, $N_s = 150$ turns and $R_L = 1 \text{ k}\Omega$, Calculate rms values and DC values of the current and voltage.

Ans: $V_{\text{rms}} = 60 \text{ V}$, $I_{\text{rms}} = 0.06 \text{ A}$, $V_{\text{dc}} = 54.04 \text{ V}$, $I_{\text{dc}} = 0.054 \text{ A}$

Five marks questions (Application):

1. A half wave rectifier uses a diode with a forward resistance of 50Ω . If the input ac voltage is 200 V rms and the load resistance is of $1 \text{ k}\Omega$, determine
 (i) I_m (ii) I_{dc} (iii) I_{rms} (iv) Ripple factor (v) Rectification efficiency

Ans: $I_m = 0.269 \text{ A}$, $I_{\text{dc}} = 0.085 \text{ A}$, $I_{\text{rms}} = 0.134 \text{ A}$, $T = 1.21$, $\gamma = 38.32 \%$

2. A 230 V, 50 Hz AC voltage is applied to the primary of 5:1 step down transformer, which is used in bridge rectifier, having a load resistance of 100 Ω . Assuming the diodes to be an ideal, determine the following:
 (i) DC output current (ii) DC output voltage (iii) DC power delivered to the load and
 (iv) PIV of each diode.

Ans: $I_{dc} = 0.41$ A, $V_{dc} = 41.4$ V, $P_{dc} = 16.8$ W, PIV = 130.1 V

3. A transformer has a 230 V primary winding and a secondary winding rated at 0–15 V (rms voltage) and is used in a full wave bridge rectifier circuit with a load of 120 Ω . What is the dc output voltage, dc load current and the PIV rating required for diodes?

Ans: $V_{dc} = 13.5$ V, $I_{dc} = 0.11$ A, PIV = 21.22 V

4. For the Zener diode voltage regulator with $V_S = 20$ V, $R_S = 100$ Ω , $V_Z = 12$ V, $R_L = 680$ Ω , determine,
 a. Load voltage
 b. Voltage drop across series resistance R_S
 c. Current through the Zener diode

Ans: $V_L = V_Z = 12$ V, $V_{R_S} = 8$ V, $I_Z = 62.35$ mA

5. Calculate the load current and Zener diode current if $V_Z = 6$ V. Given $V_S = 25$ V, $R_S = 1.5$ k Ω and $R_L = 2$ k Ω .

Ans: $I_L = 3$ mA, $I_Z = 9.6$ mA

6. In the circuit shown in fig. find the value of series resistance R_S , if Zener current is 10 mA.

Ans: $R_S = 400$ Ω

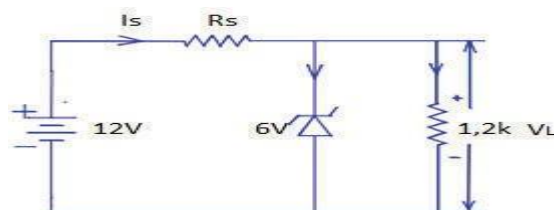

Five marks questions (Knowledge):

1. Classify solids based on energy band diagram.
2. Draw and explain the V–I characteristics of a p–n junction diode.
3. Explain the working of full wave centre tapped rectifier.
4. Explain the working of half–wave rectifier.
5. Explain the operation of bridge rectifier.
6. Explain the negative voltage rectifier.
7. Explain the working of a series inductor filter.
8. Explain the working of a shunt capacitor filter.

Five marks questions (Understanding):

1. Conduct an experiment to draw the forward and reverse characteristics of a semiconductor diode.
2. Explain the characteristics of a Zener diode.
3. Discuss the working of a Zener diode as a voltage regulator.
4. Explain the regulated +12 V DC power supply.
5. Describe the regulated –12 V power supply.

Chapter 7

Bipolar Junction Transistor

Choose the correct answer:

1.	Transistor is a (a) Bidirectional current conducting device (c) unidirectional current conducting device (c) unidirectional current conducting device	(b) passive device (d) Unipolar device
2.	BJT stands for (a) Bipolar Junction Transformer (c) Bipolar Junction Transistor (c) Bipolar Junction Transistor	(b) Bipolar Junction Transducer (d) Bipolar Junction Thyristor
3.	Current conduction in transistor is by (a) minority carriers (c) both majority and minority carriers (c) both majority and minority carriers	(b) majority carrier (d) none
4.	A transistor has (a) two layers and two junctions (c) three layer and one junction (b) three layers and two junctions	(b) three layers and two junctions (d) two layer and one junction
5.	How many PN junction does a transistor have? (a) 1 (b) 2	(b) 2 (c) 3 (d) 4
6.	Resistance of transistor (a) Collector base junction is low and emitter base junction is low (b) Collector base junction is low and emitter base junction is high (c) Collector base junction is high and emitter base junction is low (d) Collector base junction is high and emitter base junction is high (c) Collector base junction is high and emitter base junction is low	
7.	The number of pn junction in a transistor are (a) 1 (b) 2	(b) 2 (c) 3 (d) 4
8.	Which region of a transistor is physically larger in size? (a) emitter (c) collector	(b) base (c) collector (d) none of these
9.	In a transistor, the arrowhead marked terminal is called (a) base (b) emitter	(b) emitter (c) collector (d) none of these
10.	The device which transfers charge carriers from low to high resistance region is (a) resistor (c) transistor	(b) rectifier (c) transistor (d) none of these

11.	A transistor is a (a) voltage controlled device (b) current controlled device (c) collector controlled device (d) emitter controlled (b) current controlled device
12.	The emitter region of a transistor is (a) heavily doped and large in physical size (b) moderately doped and wide in physical size (c) heavily doped and medium in physical size (d) lightly doped and narrow in physical size (c) heavily doped and medium in physical size
13.	The moderately doped region of a transistor is (a) emitter (b) base (c) collector (d) none of these (c) collector
14.	The relationship between collector, base and emitter current in a transistor is (a) $I_E = I_B - I_C$ (b) $I_E = \frac{I_B}{I_C}$ (c) $I_E = I_B + I_C$ (d) $I_E = \frac{I_C}{I_B}$ (c) $I_E = I_B + I_C$
15.	If $I_C = 10$ mA and $I_B = 1$ mA, then I_E is given by (a) 1 mA (b) 9 mA (c) 10 mA (d) 11 mA (d) 11 mA
16.	For a transistor to operate in active region (a) EB junction must be forward biased and CB junction must be reverse biased (b) EB junction must be reverse biased and CB junction must be reverse biased (c) EB junction must be forward biased and CB junction must be forward biased (d) EB junction must be reverse biased and CB junction must be forward biased (a) EB junction must be forward biased and CB junction must be reverse biased
17.	Expression for α in terms of β is (a) $\alpha = \frac{\beta}{1+\beta}$ (b) $\alpha = \frac{\beta}{1-\beta}$ (c) $\alpha = \frac{1+\beta}{\beta}$ (d) $\alpha = \frac{1-\beta}{\beta}$ (a) $\alpha = \frac{\beta}{1+\beta}$
18.	Expression for β in terms of α is (a) $\beta = \frac{\alpha}{1-\alpha}$ (b) $\beta = \frac{\alpha}{1+\alpha}$ (c) $\beta = \frac{1+\alpha}{\alpha}$ (d) $\beta = \frac{1-\alpha}{\alpha}$ (a) $\beta = \frac{\alpha}{1-\alpha}$
19.	A transistor has $\alpha = 0.99$ then its β is (a) 95 (b) 98 (c) 99 (d) 100 (c) 99
20.	Knee voltage of silicon transistor is (a) 0.3V (b) 0.5V (c) 0.7V (d) 1.1V (c) 0.7V

Fill in the blanks

1.	The base region of a transistor is physically narrow and _____ doped. lightly
2.	Transistor is used for _____ purposes. amplification and switching
3.	In npn transistor consists of _____ base layer p-type
4.	In a transistor, collector current is controlled by _____ current. base
5.	An arrow in the circuit symbol of transistor indicate direction of _____ current flow. conventional
6.	In _____ current flows from emitter to collector. pnp transistor
7.	In a transistor both holes and electrons contribute to the flow of current. Hence the name _____ Bipolar
8.	Transistor operating in cut-off and saturation regions can be used in _____ application. switch
9.	In the active region, the transistor can be used as an _____ amplifier
10.	In CB configuration, the ratio of collector current to the emitter current is known as _____ α_{dc}
11.	In CE configuration, the ratio of collector current to the base current is known as _____ β_{dc}
12.	The most commonly used transistor configuration is _____ common emitter
13.	In saturation region both junctions are _____ biased. forward
14.	In cutoff region both junctions are _____ biased. reverse

One mark questions (Knowledge):

1. What is an unbiased transistor?
2. What is a biased transistor?
3. Write the symbol of a npn transistor.
4. Write the symbol of a pnp transistor.
5. What is the function of base region in a transistor?
6. What is the function of collector region in a transistor?
7. Mention the function of the emitter region in a transistor.
8. Write the physical structure of pnp transistor.
9. Write the expression showing relation between I_B , I_C and I_E of transistor.
10. Define a_{dc} of a transistor.
11. Define β_{dc} of a transistor.
12. Write one important application of a transistor.
13. Write an expression showing the relation between α and β .
14. Mention any one operating region of a transistor.

One mark questions (Understanding):

1. Why is transistor called as transfer resistor device?
2. Which region of the transistor is heavily doped?
3. Which region of the transistor is moderately doped?
4. Which region of the transistor is physically larger?
5. Which region of the transistor is physically narrow?
6. What does the arrow in the circuit symbol of a transistor indicate?
7. Why collector region is made larger?
8. How many pn junctions are there in a transistor?
9. Which operating region of a transistor is suitable for amplification?
10. Which operating region of a transistor is suitable for switching action?
11. In which mode of operation the transistor can be used as a switch?

One mark questions (Application):

1. For a transistor $I_C = 6$ mA and $I_E = 6.35$ mA, find I_B . Ans: $I_B = 0.35$ mA
2. Find the value of β , if $\alpha = 0.99$. Ans: $\beta = 99$
3. A transistor has $\beta = 100$. What is the value of α ? Ans: $\alpha = 0.99$
4. An npn transistor has a DC current gain β of 200. Calculate the base current I_B when the collector current is 4 mA. Ans: $I_B = 0.02$ mA

Two marks questions (Knowledge):

1. What are the biasing conditions of a transistor to operate in active region and cut off region?
2. Define α_{dc} of a transistor and write the expression.
3. Define β_{dc} of a transistor and write the expression.
4. Mention different configurations of a transistor.

Two marks questions (Understanding):

1. Distinguish between the doping levels of emitter and base in a transistor.
2. Why is the collector of transistor made larger and moderately doped?
3. Distinguish between α_{dc} and β_{dc} .
4. Obtain the relation between α and β of a transistor.
5. Distinguish between cut-off region and saturation region.

Two marks questions (Application):

1. In a transistor circuit, $I_E = 5 \text{ mA}$ and I_B is $1 \mu\text{A}$. Find a value of I_C and α .
Ans.: $I_C = 4.995 \text{ mA}$, $\alpha = 0.999$
2. For a transistor $I_C = 6 \text{ mA}$ and $I_E = 6.35 \text{ mA}$,
Find β .
Ans.: $I_B = 0.35 \text{ mA}$, $\beta = 17.14$
3. A transistor has $\alpha = 0.98$. If $I_C = 6 \text{ mA}$, Find I_B .
Ans.: $I_B = 0.122 \text{ mA}$
4. A transistor has $\alpha = 0.9$, if $I_E = 10 \text{ mA}$, calculate the values of I_C and β .
Ans.: $I_C = 9 \text{ mA}$, $\beta = 9$
5. In a transistor the base current and collector current is $60 \mu\text{A}$ and 1.75 mA respectively. What will be the emitter current? Calculate the values of α of a transistor.
Ans.: $I_E = 1.75 \text{ mA}$, $\alpha = 0.967$
6. A transistor has $\beta = 150$. Calculate the approximate collector and base currents if the emitter current is 12 mA .
Ans.: $\alpha = 0.993$, $I_C = 11.916 \text{ mA}$, $I_B = 0.084 \text{ mA}$
7. A transistor amplifier connected in CE mode has $\beta = 100$ and $I_B = 50 \mu\text{A}$, calculate the values of I_C and α .
Ans.: $I_C = 5 \text{ mA}$, $\alpha = 0.99$
8. A transistor has $\alpha = 0.9$, if $I_E = 10 \text{ mA}$, calculate the values of I_C and β .
Ans.: $I_C = 9 \text{ mA}$, $\beta = 9$
9. In a transistor the base current and collector current are $60 \mu\text{A}$ and 1.75 mA respectively. What will be the emitter current? Calculate the values of β of a transistor.
Ans.: $I_E = 1.75 \text{ mA}$, $\beta = 29.17$
10. A transistor connected in CE mode has $\beta = 100$ and $I_B = 50 \mu\text{A}$, calculate the values of I_C , I_E .
Ans.: $I_C = 5 \text{ mA}$, $I_E = 5.05 \text{ mA}$
11. A transistor has $I_B = 105 \mu\text{A}$ and $I_C = 2.05 \text{ mA}$. Find β and α of the transistor.
Ans.: $\beta = 19.5$, $\alpha = 0.95$
12. If α for a transistor is 0.99 , the base current is $100 \mu\text{A}$, estimate the collector current.
Ans.: $\beta = 99$, $I_C = 9.9 \text{ mA}$
13. A Transistor connected in CE mode has $\beta = 80$ and $I_C = 5 \text{ mA}$. Calculate I_E .
Ans: $I_B = 0.0625 \text{ mA}$, $I_E = 5.0625 \text{ mA}$

Three marks questions (Knowledge):

1. Explain the doping levels and physical sizes of emitter, base and collector layers.
2. List the different types of transistor configuration with necessary circuit diagram.
3. Define DC current gain in CB mode (α_{dc}), DC current gain in CE mode (β_{dc}) and Output resistance (R_o) in CE mode.
4. Describe with the diagram, the input characteristics of an npn transistor for CE configuration.
5. Briefly describe the different regions of output characteristics of transistor in CE mode.

Five marks questions (Understanding):

1. Explain with the diagram the construction and working of a npn transistor.
2. Distinguish between the different types of transistor configurations with necessary circuit diagram.
3. Distinguish between the active, saturation and cut-off regions of a transistor.
4. Explain how the input and output characteristics of an npn transistor in CE mode are drawn.

Chapter 8

Introduction to Digital Electronics

Choose the correct answer:

1.	Analog signal is defined as the signal having (a) continuous values (b) discrete values (c) step values (d) distinct values (a) continuous values
2.	A signal which can have only two discrete values is called (a) analog signal (b) digital signal (c) radio signals (d) ramp signal (b) digital signal
3.	A binary digit is called as a (a) nibble (b) word (c) bit (d) byte (c) bit
4.	A group of 4-bits is called as a (a) nibble (b) word (c) bit (d) byte (a) nibble
5.	A group of 8-bits is known as a (a) nibble (b) word (c) bit (d) byte (d) byte
6.	The number of distinct symbols used in the particular number system is termed as (a) base (b) radix (c) either (a) or (b) (d) none of these (c) either (a) or (b)
7.	The number of symbols used in binary number system are (a) two (b) four (c) eight (d) ten (a) two
8.	Hexadecimal number system has the base (a) two (b) four (c) eight (d) sixteen (d) sixteen
9.	The number of symbols used in hexadecimal number system are (a) two (b) sixteen (c) eight (d) ten (b) sixteen
10.	LSB stands for (a) Least Significant Bit (b) Lost Significant Bit (c) Long Significant Bit (d) Level Significant Bit (a) Least Significant Bit
11.	MSB stands for (a) Most Significant Bit (b) Maximum Significant Bit (c) Model Significant Bit (d) Middle Significant Bit (a) Most Significant Bit
12.	The binary equivalent of hex number F is (a) 1111 (b) 1110 (c) 1011 (d) 1001 (a) 1111
13.	The binary equivalent of the decimal number 9 is (a) 1000 (b) 1001 (c) 1010 (d) 1100 (b) 1001
14.	1's complement of the binary number 1011 is (a) 0100 (b) 1111 (c) 1010 (d) 0001 (a) 0100

15.	2's complement of the binary number 1011 is (a) 0100 (b) 0101 (c) 1010 (d) 0001 (b) 0101
16.	In 2's complement subtraction, the end around carry is to be (a) discarded (OR) ignored (b) considered (c) added to remaining bits (d) none of these (a) discarded (OR) ignored
17.	According to Boolean law $A + \bar{A}B = \underline{\hspace{2cm}}$ (a) $A+B$ (b) $\bar{A}+B$ (c) $\overline{A+B}$ (d) AB (a) $A+B$
18.	Identify basic gates (a) NOT gate (b) OR gate (c) AND gate (d) All of these (d) All of these
19.	A logic gate whose output is HIGH when any one or all of its inputs are HIGH is called (a) OR gate (b) AND gate (c) NOT gate (d) NOR gate (a) OR gate
20.	A logic gate whose output is high if and only if all of its inputs are at high is called _____ (a) OR gate (b) AND gate (c) NOT gate (d) NAND gate (b) AND gate
21.	The relation between the inputs and the outputs of a gate can be expressed mathematically by means of the (a) Boolean expression (b) Einstein's expression (c) Thevenin's expression (d) Maxwell's expression (a) Boolean expression
22.	The Logic expression for the two inputs OR gate is given by (a) $A + B$ (b) $A \oplus B$ (c) $\overline{A+B}$ (d) $\overline{A \oplus B}$ (a) $A + B$
23.	The Logic expression for the two inputs AND gate is given by (a) $A . B$ (b) $A \oplus B$ (c) $\overline{A . B}$ (d) $\overline{A \oplus B}$ (a) $A . B$
24.	The Logic expression for the NOT gate is given by (a) A (b) \bar{A} (c) $A . B$ (d) $A . B$ (b) \bar{A}
25.	The Logic expression for the two inputs NOR gate is given by _____ (a) $A + B$ (b) $A \oplus B$ (c) $\overline{A+B}$ (d) $\overline{A \oplus B}$ (c) $\overline{A+B}$
26.	The Boolean expression for the two inputs NAND gate is given by _____ (a) $A . B$ (b) $A \oplus B$ (c) $\overline{A . B}$ (d) $\overline{A \oplus B}$ (c) $\overline{A . B}$
27.	DTL stands for (a) Diode Transistor Logic (b) Diode Transformer Logic (c) Digital Timing Logic (d) Digital Transducer Logic (a) Diode Transistor Logic
28.	According to De Morgan's first theorem $\overline{\overline{A+B}}$ is equal to (a) $\overline{A . B}$ (b) $\bar{A} . \bar{B}$ (c) $\bar{A} + \bar{B}$ (d) $A + B$ (b) $\bar{A} . \bar{B}$
29.	According to De Morgan's second theorem $\overline{\overline{A.B}}$ is equals to (a) $\overline{A . B}$ (b) $\bar{A} + \bar{B}$ (c) $\bar{A} + \bar{B}$ (d) $A + B$ (b) $\bar{A} + \bar{B}$

Fill in the blanks:

1.	Signals having only two states is said to be _____ binary
2.	A square wave is an example for _____ signal digital
3.	In positive logic, high level is represented by _____ logic 1
4.	In negative logic, low level is represented by _____ logic 1
5.	Base of a number system represents maximum number of distinct ____ present in that system. symbols
6.	Bit is the abbreviation of _____ binary digit
7.	The right most bit of a binary number which has the least place value is called _____ Least Significant Bit
8.	The left most bit of a binary number which has the highest place value is called _____ Most Significant Bit
9.	Generally memory is expressed in _____ bytes
10.	1K Byte of memory contains _____ 2^{10} bytes (OR) 1024 bytes
11.	1MB of memory = _____ 2^{20} bytes (OR) 1024 KB
12.	1GB of memory = _____ 2^{30} bytes (OR) 1024 MB
13.	1T Byte of memory = _____ 2^{40} bytes (OR) 1024 GB
14.	Hexadecimal number system has _____ distinct symbols. sixteen
15.	In Boolean rule $A + \bar{A}$ is equal to (a) 0 (b) 1 (c) 10 (d) 01 (b) 1
16.	A _____ is a basic unit of a digital circuit. logic gate
17.	In a _____ gate output is complement of input. NOT
18.	NAND and NOR gates are called _____ gates. universal
19.	A table that shows all possible inputs and outputs of a logic circuit is termed as _____ truth table
20.	An astable multivibrator has _____ stable states. no

One mark questions (Knowledge):

1. What is a digital signal?
2. Define the radix or base of a number system.
3. What is the base of binary number system?
4. What is a bit?
5. What is a nibble?
6. What is a byte?
7. What is a word?
8. Expand MSB?
9. Expand LSB?
10. What is a positive logic?
11. What is a negative logic?
12. What is the purpose of 1's and 2's complement of a binary number system?
13. What is a logic gate?
14. What is a basic gate?
15. Name any one basic gate?
16. What is an OR gate?
17. What is an AND gate?
18. Write the truth table of an OR gate.
19. Write the truth table of an AND gate.
20. Write the circuit symbol of NOT gate.
21. Write the truth table of NOT gate.
22. Write the Boolean expression of NAND gate.
23. Write the Boolean expression of two inputs NAND gate.
24. Write the Boolean expression of two inputs NOR gate.
25. Write the circuit symbol of NAND gate.
26. Write the truth table of a NAND gate.
27. Write the truth table of a NOR gate.
28. Write the logic symbol of NOR gate.
29. Mention any one type of pulse generator.
30. Write the expression for frequency of astable multivibrator.

One mark questions (Understanding):

1. Give the size of 1k Byte memory.
2. How many distinct symbols are there in base 2 number system?
3. How many distinct symbols are there in base 16 number system?
4. How is 2's complement of a binary number obtained?
5. How do you represent a logic diagram using basic gates for the Boolean expression,

$$Y = \bar{A} + \bar{B}$$

One mark questions (Application):

1. Convert 85_{10} to binary number. Ans: 1010101_2
2. Convert 1001_2 into decimal number. Ans: 9_{10}
3. Convert $5DC_{16}$ into binary number. Ans: $0101\ 1101\ 1100_2$
4. Obtain the decimal equivalent of the binary number 101_2 . Ans: 5_{10}
5. Convert the given hexadecimal number $AD2_{16}$ to binary number. Ans.: $1010\ 1101\ 0010_2$
6. Convert the number 11111000_2 to hexadecimal number. Ans: $F8_{16}$
7. Convert the given number $(238)_{10}$ to hexadecimal number. Ans: EE_{16}
8. Obtain the 1's complement of the binary number 110011 . Ans: 001100_2
9. Find the 2's complement of the binary number 10101011 . Ans: 01010101_2
10. Add 110111_2 and 1101_2 . Ans: 1000100_2
11. Perform binary division 10010_2 by 11_2 . Ans: 110_2
12. Perform the binary addition for the numbers 110001 and 100001 . Ans: 1010010_2
13. Subtract $111100_2 - 11100_2$. Ans: 100000_2
14. Perform binary multiplication 1011_2 and 110_2 . Ans: 1000010_2
15. Prove that $AB+A = A$.
16. Prove that $AB+A\bar{B} = A$.
17. Simplify the expression $Y = (\bar{A}+B) (A+B) (A+1)$ using Boolean laws. Ans: $Y = B$

Two marks questions (Knowledge):

1. Distinguish between the digital and analog signals.
2. Write the circuit diagram of a transistor NOT gate.
3. Represent the truth table of NAND gate.
4. Write circuit diagram of DTL NAND gate.

Two marks questions (Understanding):

1. How is a bit represented? Give an example.
2. How is a nibble represented? Give an example.
3. How is a byte represented? Give an example.
4. How do you represent the Boolean expression and truth table of NOR-gate?
5. Why is NAND gates called as DTL circuit? Write its logic circuit.
6. Which gates are called Universal gates? Why they are called so?

Two marks questions (Application):

1. Find the Binary equivalent of $(DADA)_{16}$? Ans: $1101\ 1010\ 1101\ 1010_2$
2. Obtain the decimal equivalent and hexadecimal equivalent of the binary number $(111101)_2$.
Ans: Decimal Number= 61_{10} Hexadecimal Number = $3D_{16}$
3. Convert $(AD)_{16}$ into binary and then to decimal system.
Ans: Binary Number = $1010\ 1101_2$ Decimal Number = 173_{10}
4. Convert the given hexadecimal number $(DAC)_{16}$ to binary number and then to decimal number.
Ans: Binary = $1101\ 1010\ 1100_2$ Decimal = 3500_{10}
5. Convert the given number $(87)_{10}$ to hexadecimal number and then to binary number.
Ans: Hexadecimal Number = 57_{16} Binary Number = $0101\ 0111_2$
6. Obtain the 1's and 2's complement of the binary number 101010101_2 .
Ans: 1's complement = 010101010_2 2's complement = 010101011_2

- Prove that $\bar{A}B + A = A + B$.
- Prove that $A + BC = (A+B)(A+C)$.
- Prove that $A(A+B) = A$.
- Prove that $AB + BC + \bar{B}C = AB + C$
- Simplify the Boolean expression $Y = A + \bar{A}B + AB$.

Ans: $Y = \bar{A} + B$

Three marks questions (Knowledge):

- State and prove De-Morgan's Theorems.
- State and prove De-Morgan's Theorem with the truth table and logic circuit.
- Draw the circuit and truth table of two input diode OR gate.
- Draw the circuit and truth table of two input diode AND gate.
- Draw the circuit and the truth table of transistor NOT gate.

Three marks questions (Understanding):

- Prove that $A+BC = (A+B)(A+C)$.
- Prove that $A + \bar{A}B = A + B$.
- With the circuit diagram write the truth table of DTL NAND gate.
- With the circuit diagram write the truth table of DTL NOR gate.
- Briefly explain the circuit diagram of Astable Multivibrator.

Five marks questions (Application):

- Subtract 27_{10} from 56_{10} using 1's complement. Ans: 11101_2
- Subtract 28_{10} from 78_{10} using 1's complement. Ans: 0110010_2
- Subtract 34_{10} from 65_{10} using 2's complement. Ans: 0011111_2
- Subtract 10000_2 from 111110_2 using 2's complement. Ans: 101110_2
- Simplify the following expression, a) $Y = (\bar{A} + \bar{B})(\bar{A} + \bar{C})(\bar{B} + C)$ b) $Y = (A + \bar{B}C)(\bar{A}\bar{B} + C)$
Ans: a) $Y = \bar{A}\bar{B}$ b) $Y = A\bar{B} + AC + \bar{B}C$
- Simplify the following Boolean expression and draw the logic diagram for the simplified expression,

$$Y = \overline{\bar{A}B + A\bar{B}}$$

Ans: a) $Y = \bar{A}\bar{B} + AB$

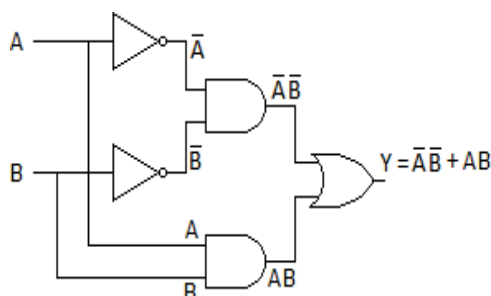

- Simplify the given Boolean expression and draw the logic circuit for the simplified answer.
 $Y = AB + ABC + AB\bar{C}$.

Ans: $Y = A \cdot B$

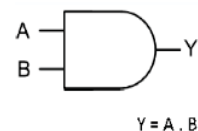

8. Simplify the given Boolean expression and draw the logic circuit for the simplified answer

$$Y = \overline{A\overline{B}} + \overline{A}B$$

Ans: $Y = \overline{A\overline{B}} + AB$

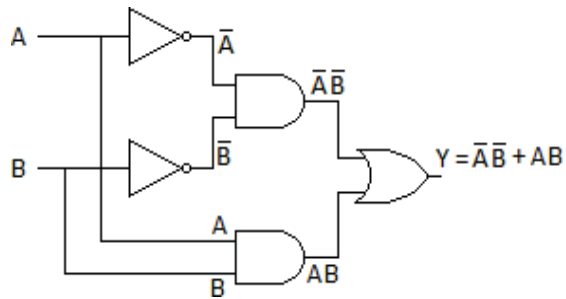

9. Simplify the Boolean expression $Y = AB + A(\overline{B} + \overline{C})$.

Ans: $Y = AB + A\overline{C}$

10. Simplify the given Boolean expression using De-Morgans' theorem,

$$Y = \overline{(\overline{A\overline{B}} \cdot A)} \cdot \overline{(\overline{A\overline{B}} \cdot B)}$$

Ans: $Y = A\overline{B} + \overline{A}B$

11. Draw the logic circuit for the given Boolean expression, $Y = A\overline{B}C + ABC + \overline{A}B\overline{C}$

Ans:

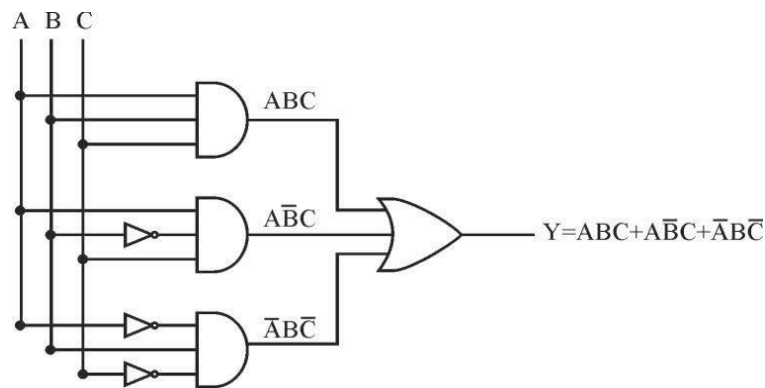

12. Draw the logic circuit for the given Boolean expression, $Y = \overline{\overline{A\overline{B}} + BC}$

Ans:

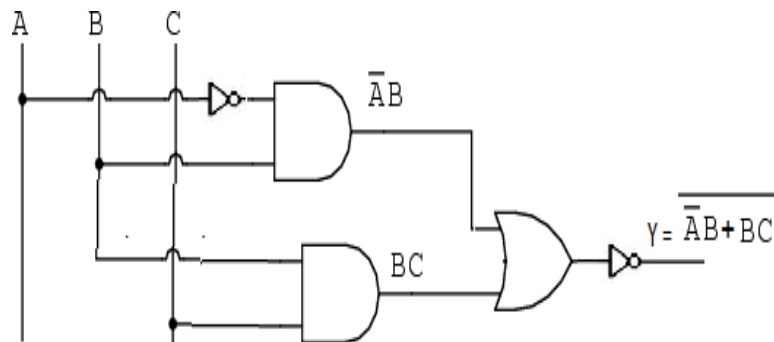

13. Simplify the Boolean expression and draw the logic circuit for the simplified answer.

a) $Y = AB + ABC + ABC\overline{C}$

b) $Y = \overline{A\overline{B}} + \overline{A}B$

Ans: a) $Y = A.B$

b) $Y = \bar{A}\bar{B} + AB$

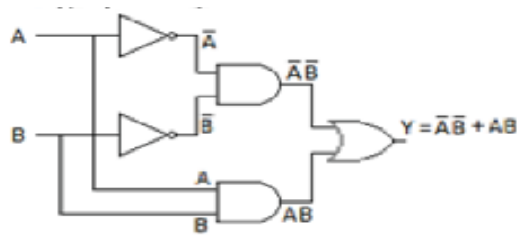
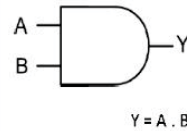

14. Simplify the Boolean Expression

$$Y = \overline{A.\bar{B} + ABC + A(B + \bar{A}\bar{B})}$$

Ans: $Y = 0$

15. (a) Find the Boolean expression for the following logic

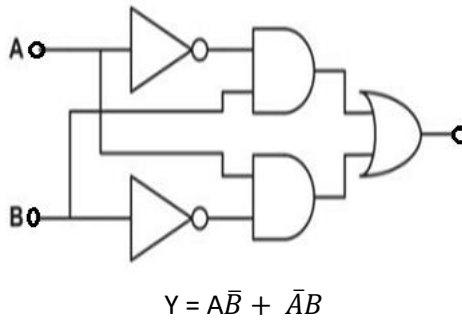

(b) Find the Boolean expression for the given logic circuit

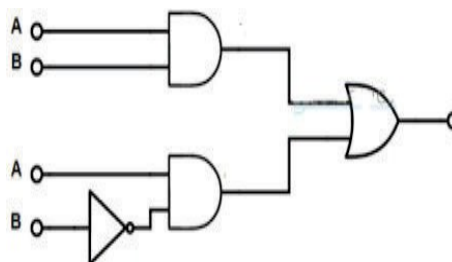

Ans: $Y = AB + A\bar{B}$

Five marks questions (Understanding):

1. State and prove De-Morgans' theorems.
2. Explain transistor NOT gate.
3. Explain two input diode OR gate.
4. Explain two inputs AND gate.
5. Explain two inputs NOR gate.
6. Explain two input NAND gate.
7. Explain astable multivibrator using IC 555.

Chapter 9

Practical Electronic Components, their specifications and PCB

Choose the correct answer:

1.	A unique code used to identify a particular electronic component or device is termed as (a) part number (b) package number (c) party number (d) none of these (a) part number
2.	A document released by the manufacturer which summarizes the technical details of an electronic device is called (a) excel sheet (b) data sheet (c) spread sheet (d) google sheet (b) data sheet
3.	The important specifications of a resistor are (a) Ohmic value (b) tolerance (c) wattage rating (d) all of these (d) all of these
4.	The capacitor having polarity is (a) electrolytic capacitor (b) disc capacitor (c) ceramic capacitor (d) paper capacitor (a) electrolytic capacitor
5.	How many pins are present in a diode bridge (1) 1pin (b) 2 pins (c) 4 pins (d) no pins (c) 4 pins
6.	The seven segment displays are available in common anode type or (a) common cathode type (b) common triode type (c) common pentode type (d) none of these (a) common cathode type
7.	PCB stands for (a) Printed Circuit Board (b) Permanent Circuit Board (c) Physical circuit Board (d) none of these (a) Printed Circuit Board
8.	Two important specifications of LEDs are : (a) voltage and current (b) weight and color (c) color and dimension (d) all of these (c) color and dimension
9.	SL-100 is a part number for (a) N-P-N transistor (b) P-N-P transistor (c) Diode (d) Zener diode (a) N-P-N transistor
10.	SK-100 is a part number for (a) N-P-N transistor (b) P-N-P transistor (c) SCR (d) Diode (b) P-N-P transistor

Fill in the blanks:

1.	The important specifications of a capacitor are capacitance value and _____ voltage rating
2.	SIP stands for _____ Single-in-line package
3.	In an IC package, if connecting pins are arranged in single row, the package type is _____ SIP
4.	DIP stands for _____ dual-in-line package
5.	An IC package provided with two parallel rows of connecting pins is called as _____ DIP
6.	Carbon Film Resistor contain _____ color bands. four
7.	Metal Film Resistor contain _____ color bands. five
8.	Fixed IC regulators provided with _____ Terminals. three
9.	78XX series regulators are called fixed _____ regulators. positive
10.	79XX series regulators are called fixed _____ Regulators. negative
11.	PCB stands for _____ Printed Circuit Board
12.	In the process of PCB designing, chemically removing all unwanted copper from the PCB is termed as _____ etching
13.	The chemicals used for etching process in PCB designing is _____ ferric chloride

One mark questions (Knowledge):

1. Write any one type of electronics packages available.
2. What is a part number?
3. Name the type of capacitor having polarity.
4. Write any one part number of a transistor.
5. Write any one part number of a diode.
6. How many pins are presents in a diode bridge?
7. Mention any one case style of transistor.
8. Mention any one part number of a positive fixed voltage regulator.
9. Mention any one part number of a negative fixed voltage regulator.
10. Expand PCB.
11. What is a trace?
12. What is a mask?

13. What is etching?
14. What is PCB layout?
15. What is single side PCB?
16. Name the chemicals used for Etching process in PCB designing.

One mark questions (Understanding):

1. What do you mean by data sheet?
2. For what application fusible resistors are used?
3. Which one is the important specification of a capacitor?
4. Write any one part number for a diode.
5. Write any one part number of Diode Bridge.

Two marks questions (Knowledge):

1. Mention the important specifications of a resistor.
2. Mention the specifications of a potentiometer.
3. Write the any two specification of a transformer.
4. Mention any two types of transistors case styles available in market.
5. Write any two specifications of LEDs.
6. Write any one part number for npn and pnp transistors.
7. Mention any two advantages of PCB.

Two marks questions (Understanding):

1. Write a brief note on specification sheet.
2. What do we understand by part number of an electronic component?
3. What information does a package details of a component give?
4. What do you mean by SIP and DIP packages?
5. Write the pin specification for 78XX regulators.
6. Write the pin specification for 79XX regulators.

Three marks questions (Knowledge):

1. List any four advantages of data sheet.
2. Write the steps involved in PCB designing.
3. Write a note on specification of a components and data sheet.
4. List the process involved in the preparation of PCB.

Three marks questions (Understanding):

1. What are the advantages of PCB?
2. Briefly explain the process of preparation of PCB.
3. List 78XX series voltage regulators.
4. List 79XX series voltage regulators.

Government of Karnataka
Department of School Education (Pre-University)
Blueprint for Model Question Papers

Subject: I PUC Electronics (40)

Sl No.	Name of the Chapter	No. of Hrs	Knowledge 35%				Understanding 35%				Application 20%				HOTS 10%	Total marks	
			1	2	3	5	1	2	3	5	1	2	3	5			
1	Introduction to Electronics	04	√				<u>F</u>	√								04	
2	Principles of electricity, Network theorems and AC principles	21	√ <u>F</u>		√		√			E				N		N	19
3	Measuring instruments	04	√					√									03
4	Passive electronic components	22	√	√		E	√ <u>F</u>		√						N		18
5	Applications of DC and AC to passive components	14	√		√		√	√						N			10
6	Semiconductors, Diodes and Applications of diodes	26	<u>F</u>	√		E	√		√	E	√					N	23
7	Bipolar junction transistor	07	√		√			√			N						07
8	Introduction to digital electronics	18	√		√		<u>F</u>			E	√	√			N		18
9	Practical electronic components, their specifications and PCB	04		√			√										03
TOTAL		120	37				37				21				10	105	

F – Fill in the blanks, HOTS – Higher order thinking, E – Essay type Question, N – Numerical Problems,

Question Paper Pattern			
Subject: I PUC Electronics (40)			
Parts	Marks per Question	Total Questions given including choices	Questions to be answered
Part A – I (MCQ)	1	15Q×1M = 15	15Q×1M = 15
Part A – II (Fill in the Blanks)	1	5Q×1M = 05	5Q×1M = 05
Part B - III	2	8Q×2M = 16	5Q×2M = 10
Part C - IV	3	8Q×3M = 24	5Q×3M = 15
Part D - V Section I (Essay Type)	5	5Q×5M = 25	3Q×5M = 15
Part D - VI Section II (Numerical)	5	4Q×5M = 20	2Q×5M = 10
		105	70

Government of Karnataka
Department of School Education (Pre University)
Model Question Paper 1
Subject: **I PUC Electronics (40)**

[Time: 3 Hours]

[Total No. of Questions: 45]

[Max. Marks: 70]

Instructions:

1. For PART-A questions, only the first written answers will be considered for evaluation.
2. Part – D consists of two sections.
Section - I is of essay type questions and Section - II is of problems.
3. Circuit diagram and truth tables must be drawn wherever necessary.
4. Solve the problems with necessary formulae.

PART A

I. Select the correct answer from the choices given: 15 x 1 = 15

1. Vacuum tube triode was invented by.
a) Shockley b) Jack Kilby c) J.A. Fleming d) Lee De Forest
2. SI Unit of charge is
a) Ampere b) Coulomb c) Faraday d) Tesla
3. Two equal value resistors each having resistance 'R' are connected in parallel, the effective resistance of the combination is equal to
a) R b) R/2 c) 2R d) 2/R
4. Sphygmomanometer is an instrument used to measure
a) Glucose b) Hemoglobin c) Temperature d) Arterial pressure
5. Identify the active device amongst the following
a) Transistor b) Resistor c) Capacitor d) Inductor
6. The ability of a capacitor to store electrical charges is known as
a) resistivity b) resistance c) conductance d) capacitance
7. In an RC circuit connected to DC source, voltage across the capacitor increase
a) Linearly b) Exponentially
c) Constantly d) Logarithmically
8. For a series LCR circuit condition for resonance is
a) $X_L > X_C$ b) $X_L < X_C$ c) $X_L = X_C$ d) $X_L \neq X_C$
9. Barrier voltage for Silicon diode is
a) 0.3V b) 0.5V c) 0.6V d) 0.7V
10. A centre tapped full wave rectifier consists of
a) One diode b) Two diodes c) Three diodes d) Four diodes

11. Number of junctions in a transistor is
 a) zero b) one c) two d) three
12. A transistor has $\alpha = 0.99$ then its β is given by
 a) 95 b) 98 c) 99 d) 100
13. A group of four bits is called
 a) Bit b) Byte c) Word d) Nibble
14. Logic expression for the output of NOR gate is
 a) $Y = \overline{A B}$ b) $Y = \overline{A + B}$ c) $Y = AB$ d) $Y = \overline{A B}$
15. Technical specifications document of a component is called
 a) Data sheet b) Excel sheet c) Google sheet d) Work sheet

II. Fill in the blanks by choosing appropriate answer from those given in the bracket:

5 x 1 = 5

[a) filter b) frequency c) digital d) chopper e) transistor f) potentiometer]

16. DC to DC converters are called
17. Number of AC cycles completed in one second is called
18. Example for a variable resistor is
19. The circuit which eliminates ripples is called
20. A square wave is an example for the signal.

PART B

III. Answer any FIVE questions:

5 x 2 = 10

21. Silicon is more preferred than germanium in semi conductor devices fabrication, justify.
22. Mention any two advantages of digital thermometer.
23. Distinguish between self inductance and mutual inductance.
24. Draw the graph showing growth of current in RL circuit.
25. Mention any two applications of a diode.
26. What are the biasing conditions of a transistor to operate in active region and in cut off region?
27. Prove that $A + \overline{A}B = A + B$
28. Mention two important specifications of LED.

PART C

IV. Answer any FIVE questions:

5 x 3 = 15

29. Mention any three properties of charges.
30. How do you create 3 V, 2 V and 1 V from a 3 V source?.
31. Explain the construction of carbon composition resistor.

32. In a series RLC circuit explain variation of impedance with reference to frequencies.
33. What is the reactance of a $3 \mu\text{H}$ inductor connected to an AC of 230 V, 50 Hz?
34. Write a note on formation of n-type semiconductor.
35. Compare the doping levels and physical sizes of emitter, base and collector layers of a transistor.
36. State and prove De-Morgan's Theorems.

PART D (Section I)

V. Answer any THREE questions: **3 x 5 = 15**

37. Derive an expression for the effective resistance of two resistors connected in series.
38. Explain the construction and working of loudspeaker.
39. Classify solids based on energy band diagram.
40. Construct a bridge rectifier circuit and explain.
41. Explain working of two input diode AND gate.

PART D (Section II)

VI. Answer any TWO questions: **2 x 5 = 10**

42. Using Thevenin's theorem, find the load current and load voltage for the following circuit.

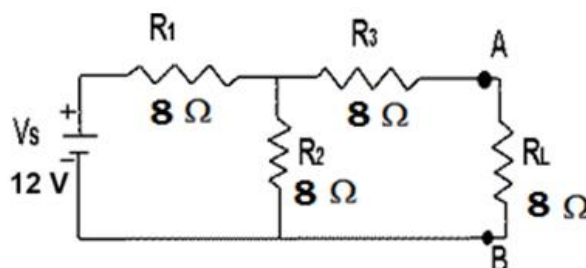

43. A transformer has 500 turns in the primary and 250 turns in the secondary. What is the turn's ratio? How much is the secondary voltage with a primary voltage of 230 V?
44. For the Zener diode voltage regulator with $V_s = 20 \text{ V}$, $R_s = 100 \Omega$, $V_Z = 12 \text{ V}$, $R_L = 680 \Omega$. Determine
 - a. Load voltage
 - b. Voltage drop across series resistance R_s
 - c. Current through the Zener diode
45. Subtract 1111_2 from 11001_2 using 2's complement method. Also verify the same by direct subtraction method.

Government of Karnataka
Department of School Education (Pre University)
Model Question Paper - 2
Subject: **I PUC Electronics (40)**

[Time: 3 Hours]

[Total No. of Questions: 45]

[Max. Marks: 70]

Instructions:

1. For PART-A questions, only the first written answers will be considered for evaluation.
2. Part – D consists of two sections.

Section - I is of essay type questions and Section - II is of problems.

3. Circuit diagram and truth tables must be drawn wherever necessary.
4. Solve the problems with necessary formulae.

PART A

I. Select the correct answer from the choices given

15 x 1 = 15

1. How many electrodes are present in a vacuum tube triode?
a) One b) Two c) Three d) Four
2. Kirchoff's Voltage law is also called as
a) current rule b) node rule c) loop rule d) mesh rule
3. Commercial unit of electric energy is
a) Kilowatt-hour b) Kilojoule-second
c) Megawatt-hour d) Megajoule-hour
4. Instrument used to display electrical signals is
a) CRO b) ECG c) LCD d) DMM
5. The resistance of an SMD resistor with code 223 is
a) 223Ω b) 22.3Ω c) $22 \text{ k}\Omega$ d) $22.3 \text{ k}\Omega$
6. Carbon microphone is an example of
a) Resistor b) Inductor c) Transformer d) Transducer
7. For a series RLC circuit, the impedance Z at resonance frequency is given by
a) $Z = X_L$ b) $Z = X_C$ c) $Z = R$ d) $Z = X_L + X_C$
8. The phase difference between voltage and current in a purely inductive circuit is
a) 0° b) 90° c) 180° d) 360°
9. Barrier voltage of Germanium diode is
a) 0.3 V b) 6 V c) 0.7 V d) 1.1 V
10. Zener diode is usually operated in
a) Reverse bias b) Zero bias c) Forward bias d) No bias
11. The heavily doped region of a transistor is
a) Emitter b) Collector c) Base d) Gate

12. If $I_C = 10 \text{ mA}$ and $I_B = 1 \text{ mA}$, then I_E is equals to
 a) 11 mA b) 9 mA c) 10 mA d) 1 mA
13. The binary equivalent of the hex number F is
 a) 1111 b) 1110 c) 1011 d) 1001
14. Expression for two input AND gate is
 a) $Y = A+B$ b) $Y = AB$ c) $Y = A/B$ d) $Y = A-B$
15. Identify the PCB fabrication process.
 a) Etching b) Welding c) Shielding d) Fusing

II. Fill in the blanks by choosing appropriate answer given in the bracket. 5 x 1 = 5

[a) memory b) logic gate c) resistor d) battery e) trimmer f) intrinsic]

16. ROM and RAM are the types of _____.
17. A combination of cells is a _____.
18. Example of a variable capacitor is _____.
19. Semiconductor in its purest form is called _____ semiconductor.
20. A _____ is a basic unit of digital circuit.

PART B

III. Answer any FIVE questions

5 x 2 = 10

21. Mention any two applications of Internet.
22. Write any two merits of multimeter.
23. Explain the construction of air core inductor.
24. Draw the graph showing voltage across capacitor during charging in RC circuit.
25. What is ideal diode? Draw the VI characteristics of an ideal diode.
26. Define the DC current gains α and β of a transistor.
27. Draw the logic circuit for the Boolean expression $Y = (A+B) (B+C)$.
28. Write any one part number for NPN and PNP transistors.

PART C

IV. Answer any FIVE questions

5 x 3 = 15

29. Explain voltage divider rule.
30. Given peak voltage is 5 V and time period is 20 ms. Calculate V_{p-p} , V_{rms} and frequency of AC waveform.
31. Derive an expression for the equivalent capacitance of three capacitors connected in parallel.

32. Write the circuit diagram and expression for cut-off frequency of a low pass filter.
33. A 2.5 mH inductor is placed in a circuit where the frequency is 100 KHz and peak voltage is 50 V. Calculate inductive reactance and peak current.
34. Explain the formation of a p type semiconductor.
35. Distinguish between the active, cut-off and saturation regions of the transistor characteristics.
36. Write the logic symbol, logic expression and truth table of a two input NAND gate.

PART D (Section I)

V. Answer any THREE questions:

3 x 5 = 15

37. State and explain Thevenin's theorem.
38. Explain the construction of metal film resistor.
39. Explain the working of a p-n junction under forward bias.
40. Draw a neat circuit diagram and explain the working of a half wave rectifier.
41. What is a NOT gate? Explain the working of a transistor NOT gate with circuit diagram.

PART D (Section II)

VI. Answer any TWO questions:

2 x 5 = 10

42. Determine the branch currents and voltage drop across each resistor for the given circuit.

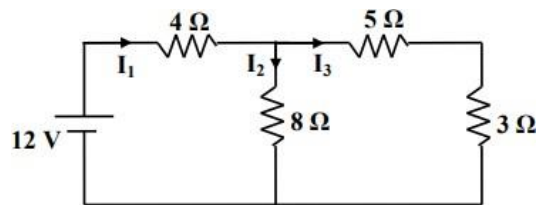

43. Two capacitors of 60 μ F each are connected in parallel. The combination is further connected in series with two capacitors of 30 μ F and 75 μ F. Calculate the total capacitance of the circuit.
44. For the zener diode voltage regulator, find the value of series resistance R_s if zener current is 10 mA.

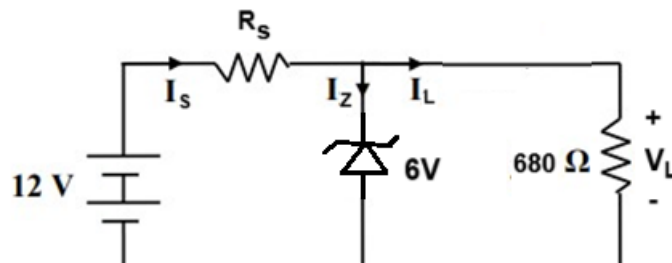

45. Subtract 24_{10} from 67_{10} using 2s complement method. Verify the same by direct subtraction method.

Government of Karnataka
Department of School Education (Pre University)
Model Question Paper - 3
Subject: **I PUC Electronics (40)**

[Time: 3 Hours]

[Total No. of Questions: 45]

[Max. Marks: 70]

Instructions:

1. For PART-A questions, only the first written answers will be considered for evaluation.
2. Part – D consists of two sections.
Section - I is of essay type questions and Section - II is of problems.
3. Circuit diagram and truth tables must be drawn wherever necessary.
4. Solve the problems with necessary formulae.

PART A

I. Select the correct answer from the choices given

15 x 1 = 15

1. The workhorse of analog electronics is
a) BJT b) Diode c) FET d) Op-amp
2. AC generator uses the principle of
a) Electromagnetic radiation b) Electromagnetic energy
c) Electromagnetic induction d) Electromagnetic wave
3. SI unit of electric power is
a) Joule b) Coulomb c) Watt d) Volt
4. The electronic instrument used to measure saturation level of haemoglobin is
a) Digital Thermometer b) Multimeter
c) Glucometer d) Pulse Oximeter
5. The fourth band of a 4 band colour resistor indicates
a) Tolerance b) Efficiency c) Accuracy d) Precision
6. The capacitor which is sensitive to polarity is
a) Ceramic capacitor b) Polystyrene capacitor
c) Ganged capacitor d) Electrolytic capacitor
7. When AC is applied to a pure resistor, the voltage and current are
a) In phase b) Out of phase
c) V leads I d) I leads V
8. The circuit that allows all frequencies below cutoff frequency is
a) High Pass Filter b) Series Inductor Filter
c) Low Pass Filter d) Capacitor Filter

9. The majority charge carriers in P-type semiconductor are
 a) holes b) electrons c) protons d) neutrons
10. Which of these components is used in rectifier with filter circuit?
 a) Transformer b) Capacitor
 c) Diode d) all of these
11. How many PN junctions does a transistor have?
 a) 1 b) 2 c) 3 d) 4
12. A transistor has $\beta = 100$. What is the value of α ?
 a) 0.96 b) 0.97 c) 0.98 d) 0.99
13. One kilobytes of memory equals
 a) 1024 bytes b) 1024 words c) 1024 bits d) 1024 nibbles
14. Which of these gates is called universal gate?
 a) OR gate b) NAND gate c) AND gate d) NOT gate
15. Identify the important specification of a resistor.
 a) Power rating b) Frequency rating c) Voltage rating d) Current rating

II. Fill in the blanks by choosing appropriate answer given in the bracket. 5 x 1 = 5

[a) integrated circuit b) binary digit c) current d) square e) voltage regulator f) inductor]

16. An entire electronic circuit on a single chip is called_____.
17. An example of non-sinusoidal waveform is _____ wave.
18. A choke is an example of_____.
19. A zener diode can be used as a _____.
20. Bit is the abbreviation of_____.

PART B

III. Answer any FIVE questions 5 x 2 = 10

21. Write a brief note on the defence application of electronics.
22. What is a CRO? Mention its application.
23. Name the factors on which the inductance of a coil depends.
24. AC is applied to pure resistor. Draw 'v' and 'i' waveforms.
25. Draw the circuit diagram of +12 V voltage regulator circuit.
26. List the configurations of a transistor.
27. Simplify the equation $Y = AB + A(\overline{B + C})$
28. List any two advantages of PCB.

PART C

IV. Answer any FIVE questions

5 x 3 = 15

29. Explain how a current source is converted into a voltage source.
30. Find out the total current and total resistance in the circuit given below.

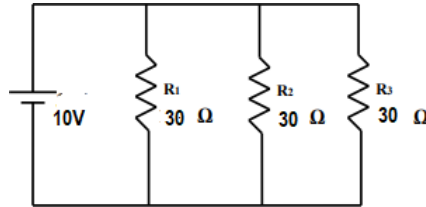

31. Mention the different types of transformers.
32. Discuss the charging of a capacitor in a RC circuit. Define time constant of a RC circuit.
33. A 10Ω resistor is in series with $X_L = 50 \Omega$ and $X_C = 25 \Omega$. The applied voltage is 50 mV with 50 Hz. Calculate the impedance (Z) and current.
34. Explain the working of shunt capacitor filter.
35. Explain the working of a npn transistor.
36. Draw circuit diagram and truth table of two input OR gate.

PART D (Section I)

V. Answer any THREE questions:

3 x 5 = 15

37. Mention the properties of charges.
38. Explain the construction of a carbon composition resistor.
39. Draw VI characteristics of p-n junction diode.
40. Explain the action of a series positive clipper.
41. With a neat circuit diagram, explain the working of a DTL NOR gate.

PART D (Section II)

VI. Answer any TWO questions:

2 x 5 = 10

42. What should be the value of R_L to obtain maximum power? How much power is transferred to R_L ?

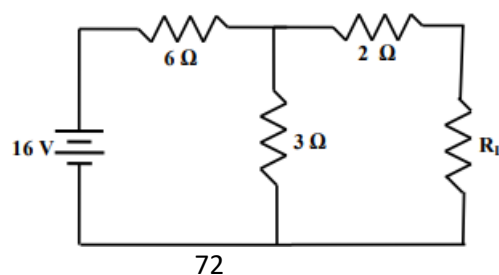

43. Two capacitors of capacitances 3 pF and 12 pF are connected in parallel across a 30 V DC supply. Determine
- a) Effective capacitance of the combination
 - b) Charge on each capacitor
 - c) Total charge of the combination.
44. A half wave rectifier uses a diode with a forward resistance of 50 Ω . If the input AC voltage is 230 Vrms and the load resistance is 1 k Ω , determine
- a) I_m , I_{rms} and I_{DC}
 - b) PIV
 - c) AC input power and DC output power.
45. Subtract 12_{10} from 58_{10} using 2s complement method. Verify the same by direct subtraction method.
